

**POINT AND CLICK CURSOR TOWARD THE CENTER
OF THE BLACK BOX TO SEE VIDEO CLIP OF THE
HEBREW SANCTUARY**

SANCTUARIES - TEMPLES

2 CORINTHIANS 6:16

And what agreement hath the temple of God with idols? for ye are the temple of the living God; as God hath said, I will dwell in them, and walk in [them]; and I will be their God, and they shall be my people.

EXODUS 25:8

And let them make me a sanctuary; that I may dwell among them.

PSALMS 77:13

Thy way, O God, [is] in the sanctuary: who [is so] great a God as [our] God?

COLOSSIANS 1:19, 20

For it pleased [the Father] that in him should all fulness dwell; And, having made peace through the blood of his cross, by him to reconcile all things unto himself; by him, [I say], whether [they be] things in earth, or things in heaven.

THE PLAN OF SALVATION

LAMB



Jesus paid the penalty of our sins.

The wages of sin is death (Rom. 6:23)

Who were resurrected by His death, were raised again by His life (Romans 7:4)



LAW

But in the inauguration of the law (1 John 1:10)



SANCTUARY

That makes the law to us (John 1:17)

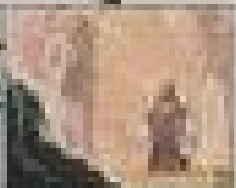

PRIEST

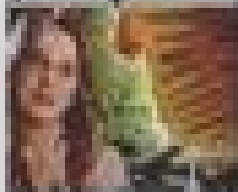

THE SANCTUARY

It is my prayer that each of us will be in that circle of God's love, in joyful relationship with Jesus. When we are, we will want to tell our friends and anyone else about it. Heaven will begin right here in our hearts (John 5:24)

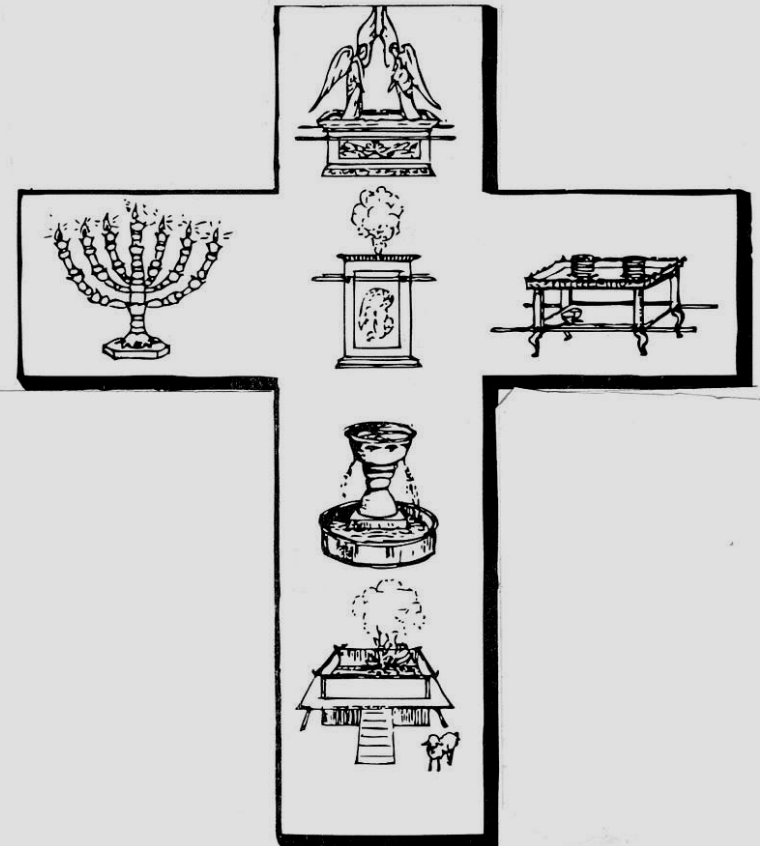

The *sanctuary* furniture from the *bronze altar* in the court to the *ark* in the *Most Holy Place* is laid out in the form of a cross. Walking through the *sanctuary* spiritually is following a path from Eden lost back to the *throne* of God.

SANCTUARY BLUE PRINT

EXODUS:25-40



SOLOMON'S TEMPLE

1 KINGS 6-7 & 2 CHRONICLES 2-7



TEMPLE BUILT BY SOLOMON C. 950 BC

ZERUBBABEL'S TEMPLE

HAGGAI 2:3-9 & JOHN 2:20



EZEKIEL'S TEMPLE

EZEKIEL 40-43



TEMPLE OF EZEKIEL'S VISION C. 570 BC
(NEVER BUILT)

JESUS' TEMPLE- BODY

JOHN 2:19-21



Our God is...

Daniel 3:17

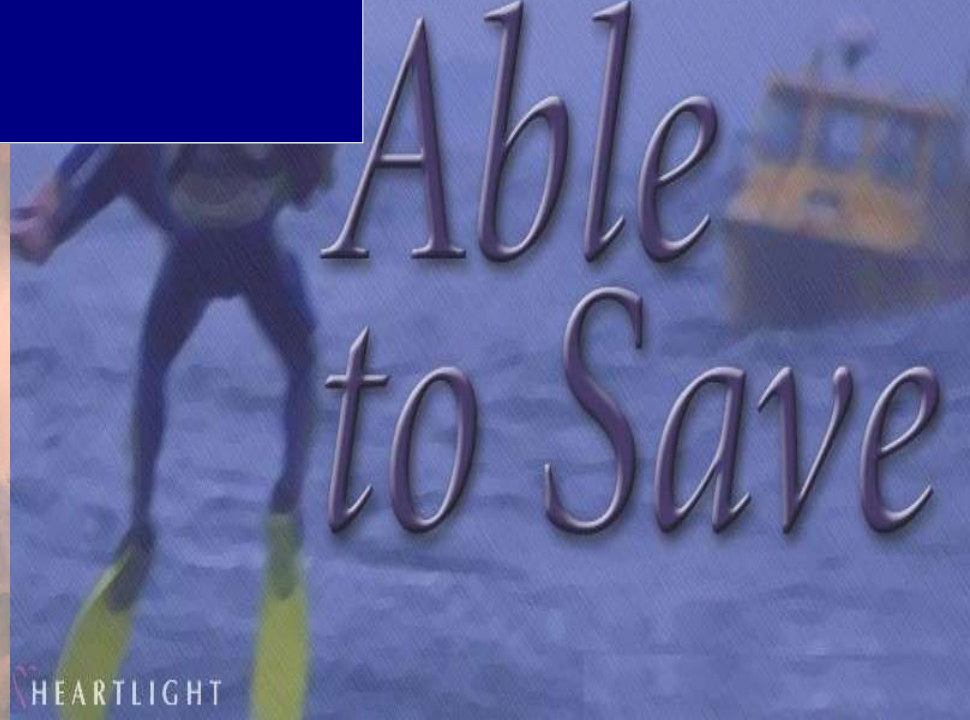

*Able
to Save*

THE CHRISTIAN'S CHURCH- TEMPLE
EPHESIANS 2:19-21 & 1 PETER 2:4-10



EACH CHRISTIAN - TEMPLE

1 CORINTHIANS 6:19, 20 & 3:16, 17



HUMAN BODY PROTEIN - LAMININ

IT WORKS LIKE CRAZY GLUE

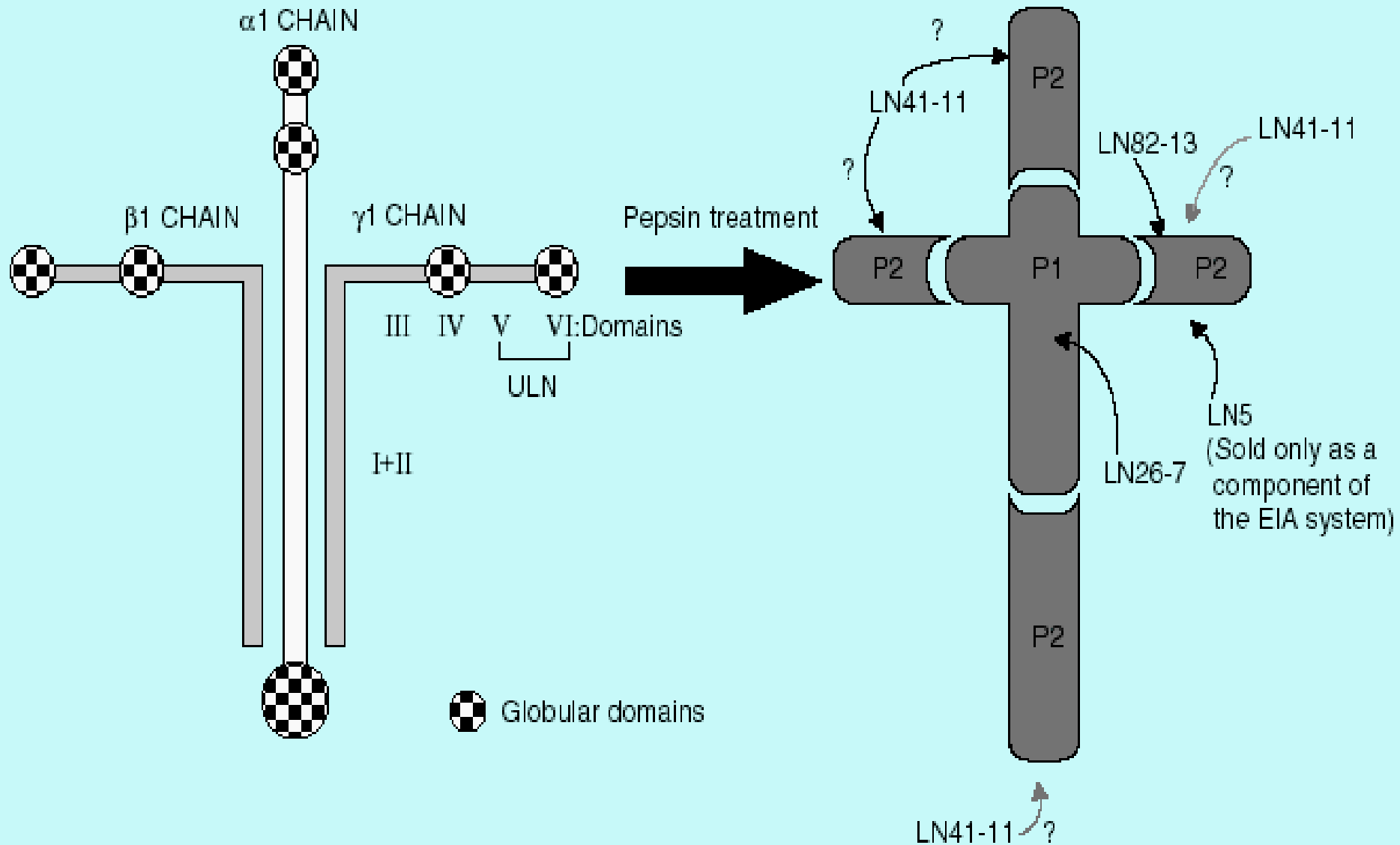

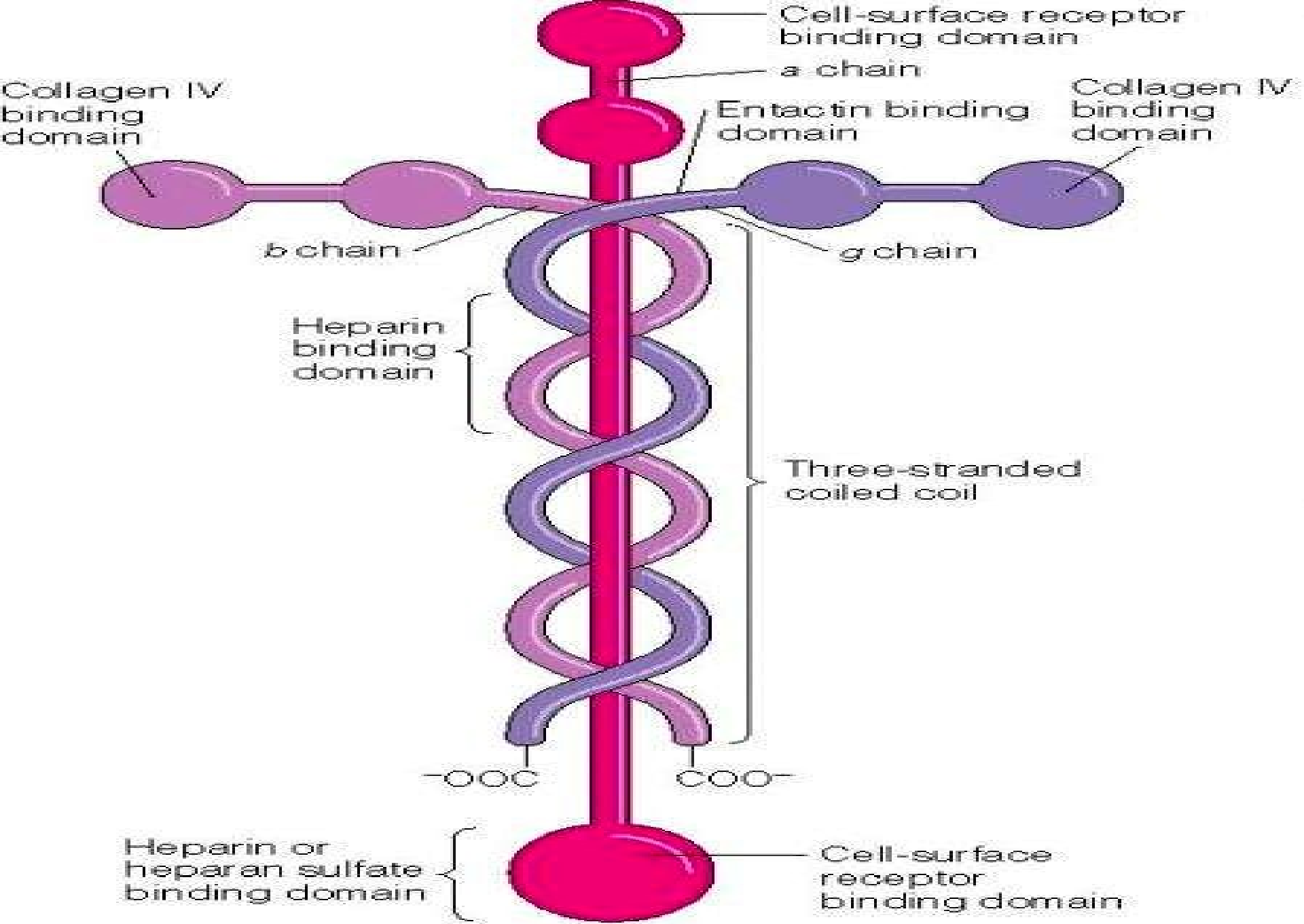

LAMININ - MICROSCOPE

POSSIONS 1:14, 17, 19, 20, 27

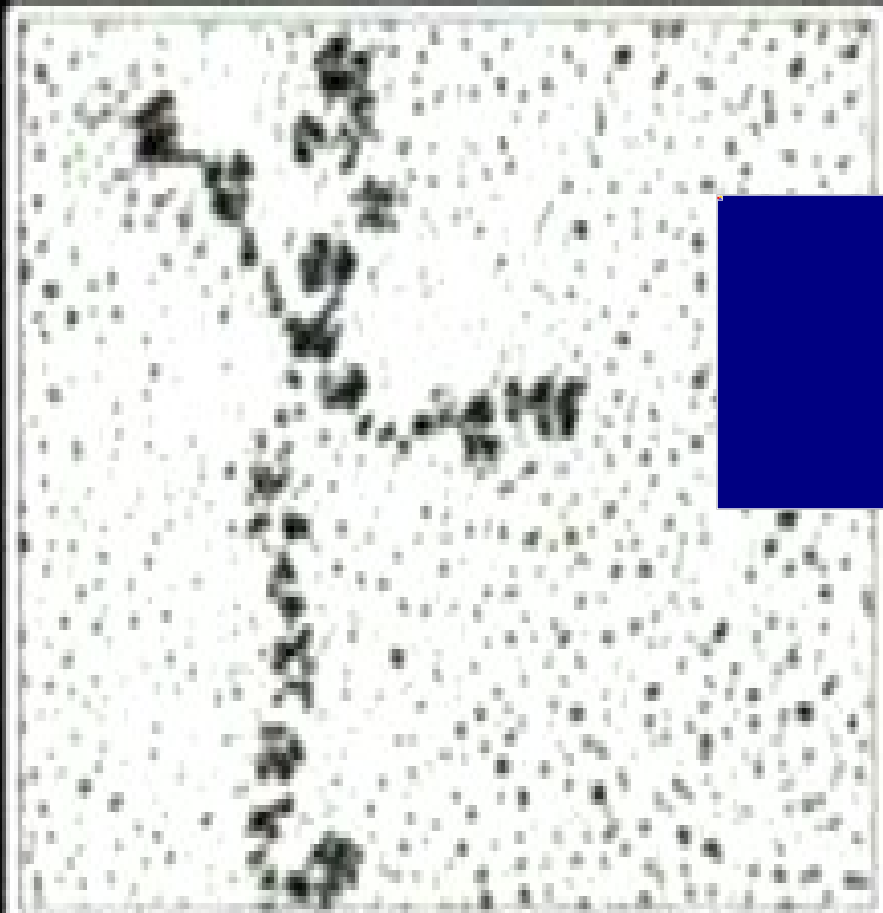

(Laminin)



HEAVENLY SANCTUARY—TEMPLE

ORIGINAL: HEBREWS 8:1-5 & EXODUS 25-40



SPIRIT OF PROPHECY: ACTS 3:17

NO EXCUSE FOR WILLFUL IGNORANCE

"I wot that through ignorance ye did it," said Peter; but this ignorance did not excuse the action; for they had had great light granted unto them. The statement is made that had they known that He was the Prince of life, they would not have crucified Him. But why did they not know?—because they chose not to know. They had no interest to search and study, and their ignorance proved their eternal ruin. They had had the strongest evidence on which to base their faith, and they were under obligation to God to accept the evidence He had given them. Their unbelief made them guilty of the blood of the only begotten Son of the infinite God (MS 9, 1898). {6BC 1056.3}

1 CORINTHIANS 3:11

For other foundation can no man lay than that is laid, which is Jesus Christ.

TWO FOUNDATIONAL PRINCIPLES—HEBREW SANCTUARY

- THE HEBREW SANCTUARY: COPY—OLD TESTAMENT (WILDERNESS—MOSES)

- THE HEAVENLY SANCTUARY: ORIGINAL IN THE NEW TESTAMENT (HEAVEN—JESUS)

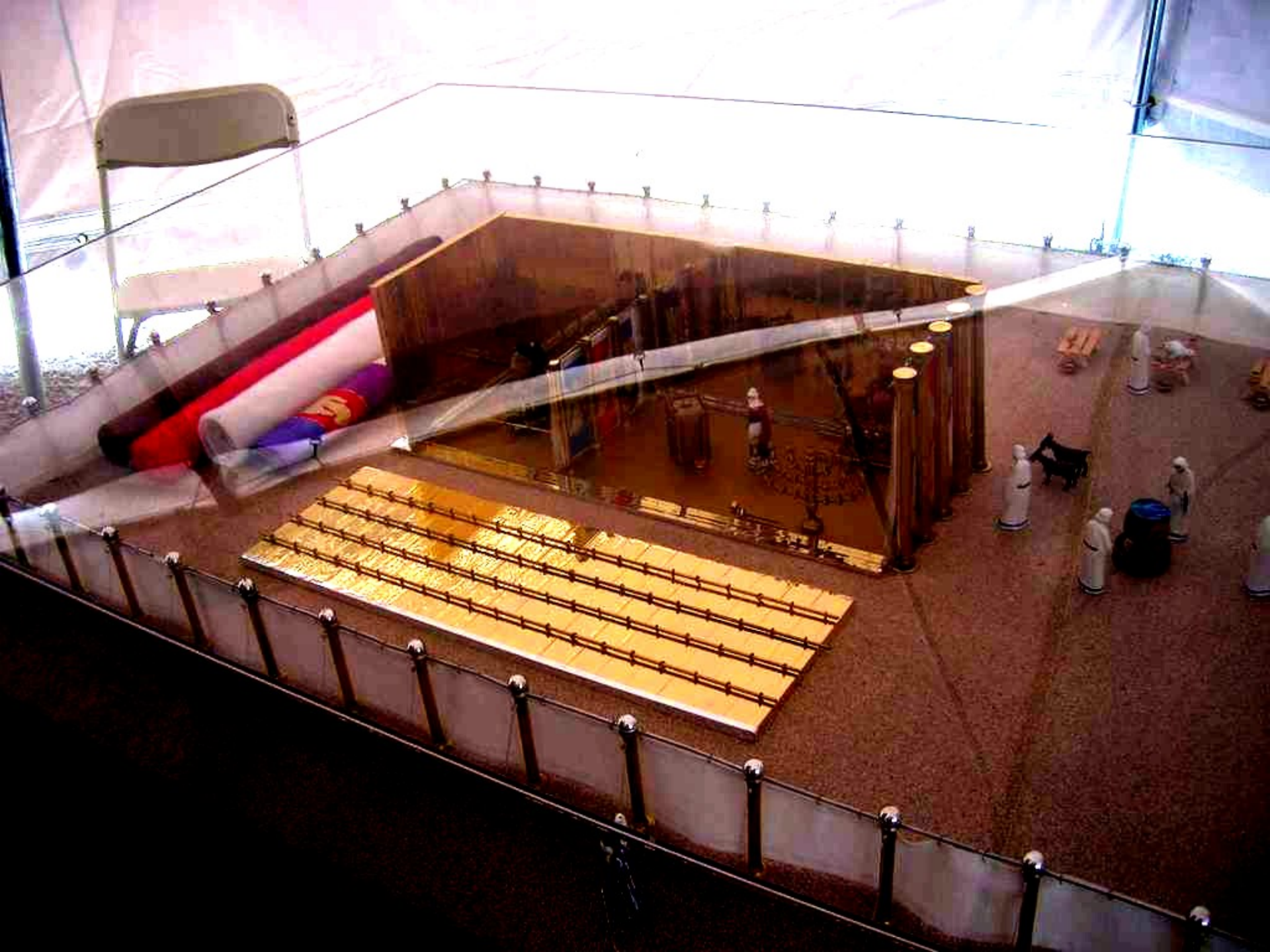

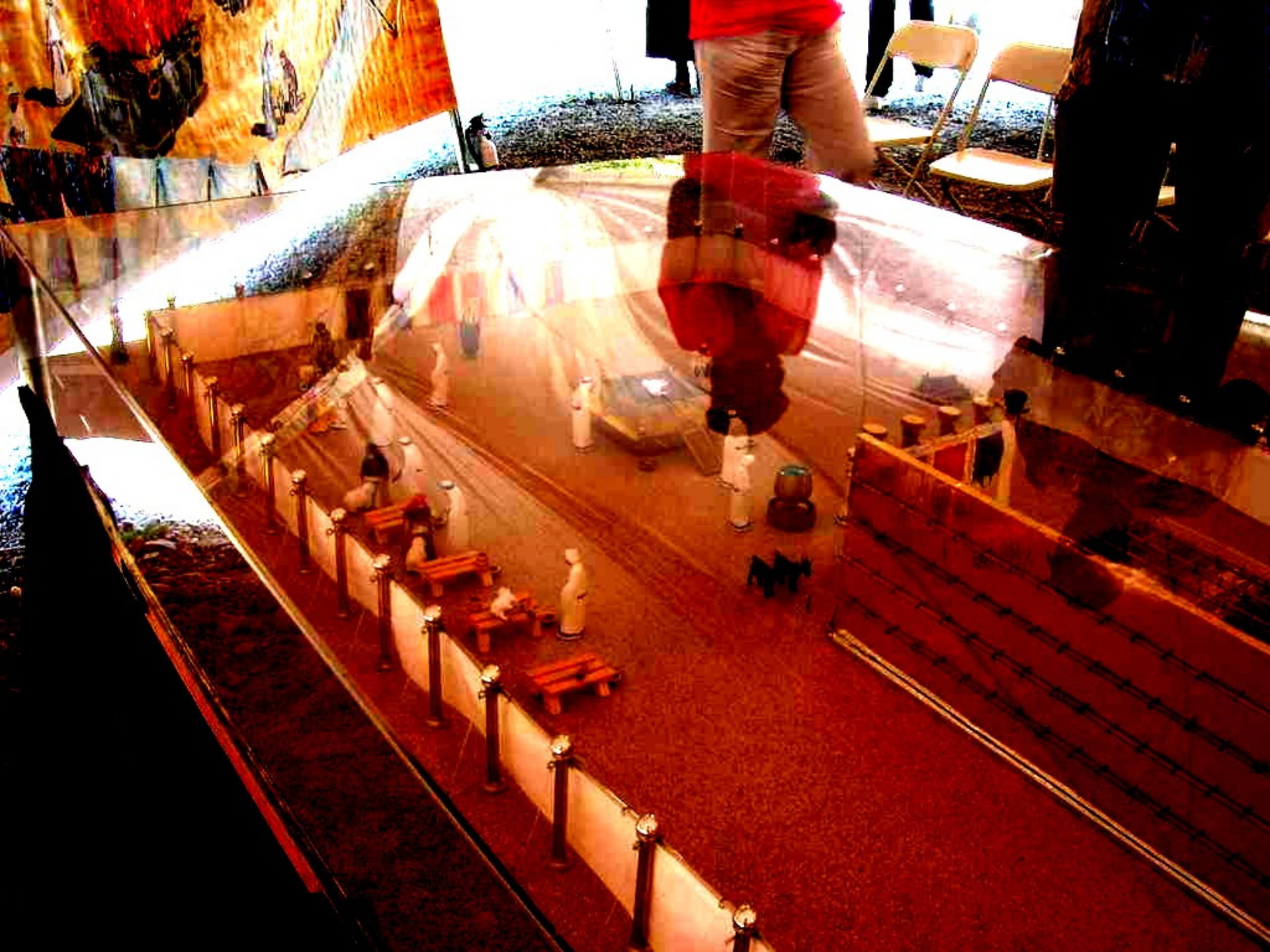

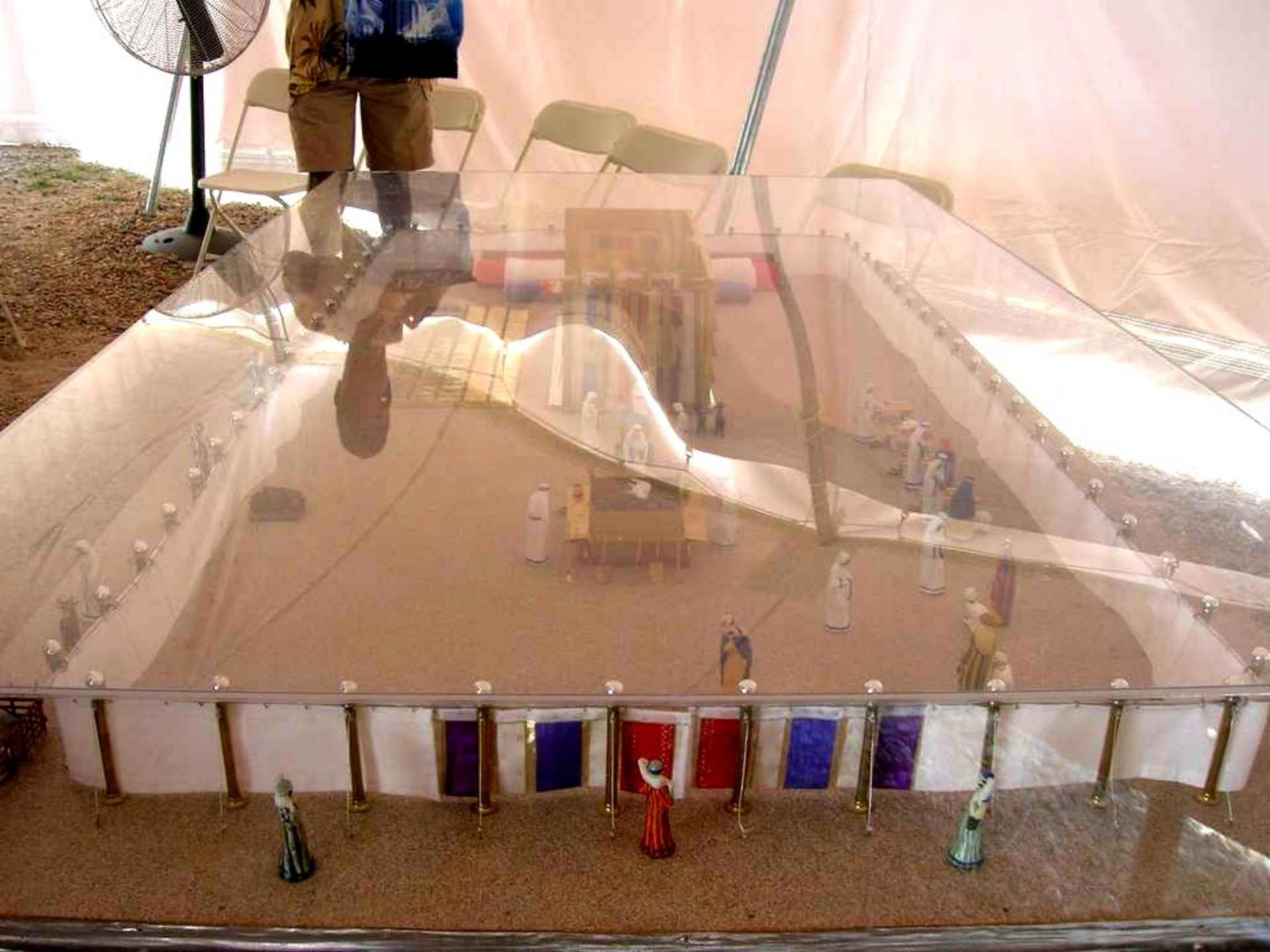









THE HEBREW SANCTUARY PATTERN - REVELATION - JESUS

JESUS

JESUS HAS BEEN **FOLLOWING** AND **APPLYING** THAT
SAME PATTERN **STEP BY STEP** FROM BEGINNING TO
END—ON **EARTH AND IN HEAVEN**

WE MUST **UNDERSTAND** THE SANCTUARY MESSAGE—TO
BE ABLE TO FOLLOW OUR HIGH PRIEST **STEP BY STEP**
THROUGH THE HEAVENLY SANCTUARY (**SPIRITUALLY**)

FOUR COMPARTMENTS: HEBREW SANCTUARY

1. THE ENCAMPMENT

- ISRAELITES—DWELL IN TENTS
- ISRAELITES—PART OF THE SANCTUARY ITSELF

EXODUS 25:8

And let them make me a sanctuary; that I may dwell among them.



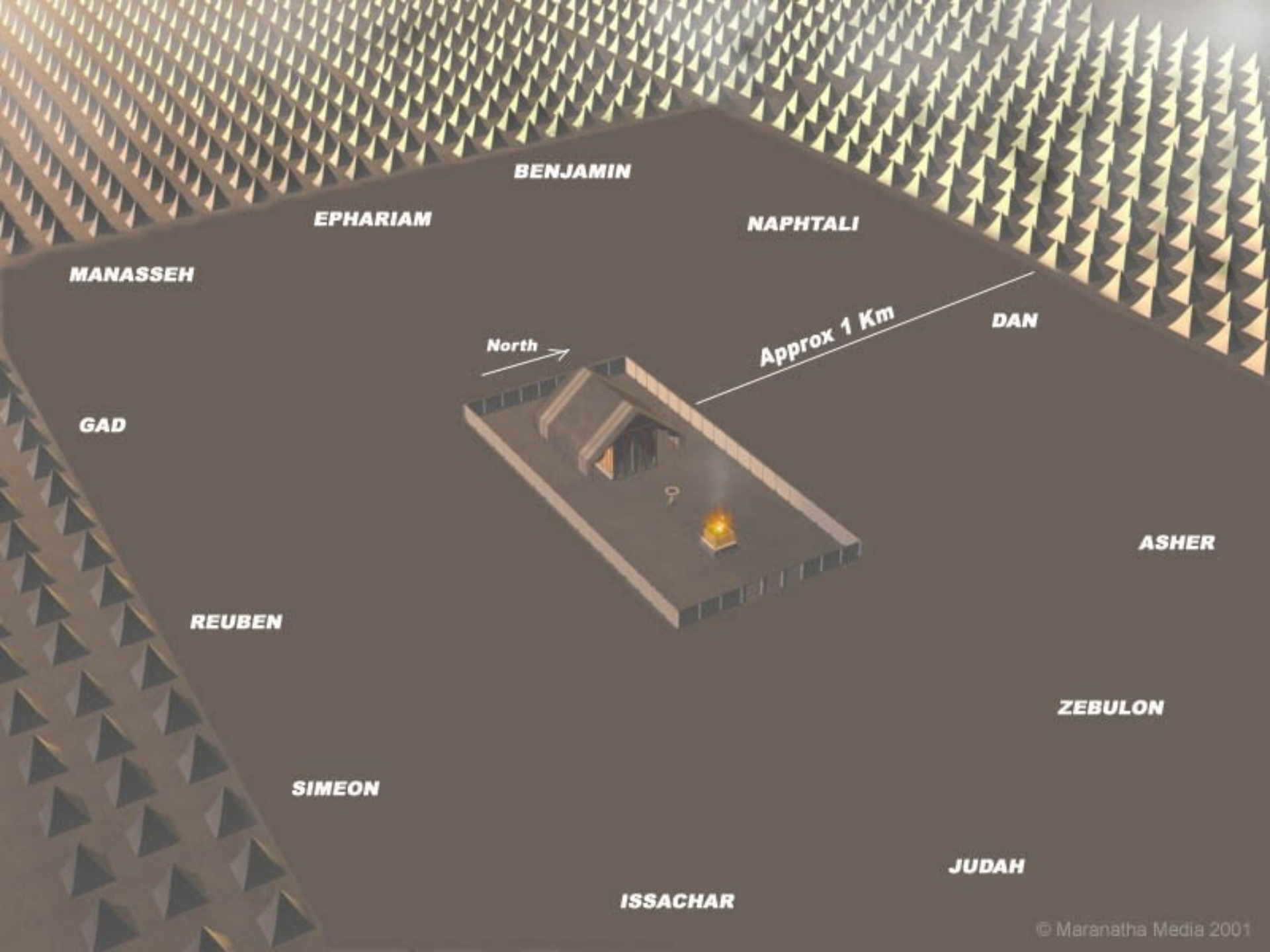

BENJAMIN

EPHARIAM

NAPHTALI

MANASSEH

DAN

North →

Approx 1 Km

GAD

ASHER

REUBEN

ZEBULON

SIMEON

JUDAH

ISSACHAR



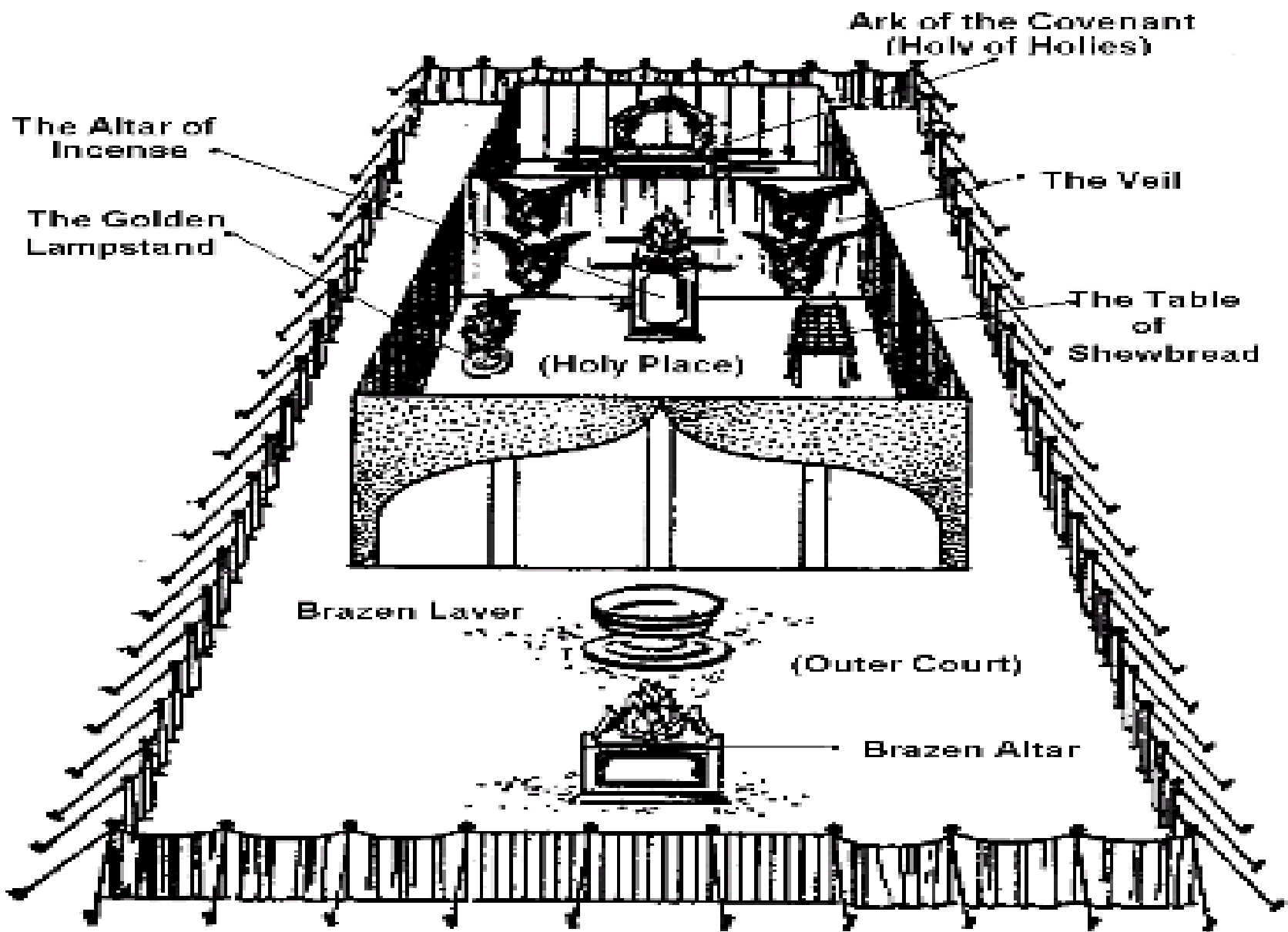

FOUR COMPARTMENTS: HEBREW SANCTUARY

2. THE COURTYARD

□ THE COURTYARD'S DESCRIPTION

EXODUS 38:9-20

EXODUS 27:18

EZEKIEL 8:15, 16 IS
COUNTER WORSHIP

□ ALTAR OF SACRIFICE

□ LAVER—WASHING



FOUR COMPARTMENTS: HEBREW SANCTUARY

THE COURTYARD'S PERSONAL APPLICATION

ALTAR OR SACRIFICE

- CHRIST WANTS TO HELP US TO DIE TO SELF
- CHRIST WANTS TO HELP US SACRIFICE OUR LIVES TO SAVE OTHERS
- CHRIST WANTS TO CONSUME SIN IN OUR LIVES

LAVAR—SYMBOLIZES THE WATERY GRAVE OF A BAPTISMAL RESURRECTION INTO NEWNESS OF LIFE IN CHRIST



FOUR COMPARTMENTS: HEBREW SANCTUARY

THE COURTYARD MESSAGE

- ❑ RECONCILIATION BETWEEN GOD AND MAN
- ❑ WE RECEIVE JUSTIFICATION AND CLEANSING THROUGH THE IMPUTED RIGHTEOUSNESS OF CHRIST
- ❑ TO BE BORN AGAIN—BAPTISM IS A NEW WAY OF LIVING—BEHAVING—THINKING—SEEING—SPEAKING—WORSHIPPING—ETC)

READ ISAIAH 1:18
REVELATION 19:8



SPIRIT OF PROPHECY: SONS AND DAUGHTERS OF GOD, P. 101

God Promises Us a New Heart of Flesh—EZEKIEL 36:26

The youth especially stumble over this phrase, "A new heart." They do not know what it means. They look for a special change to take place in their feelings. This they term conversion. Over this error thousands have stumbled to ruin, not understanding the expression, "Ye must be born again." . . . When Jesus speaks of the new heart, He means the mind, the life, the whole being. To have a change of heart is to withdraw the affections from the world, and fasten them upon Christ. To have a new heart is to have a new mind, new purposes, new motives. What is the sign of a new heart?—a changed life. There is a daily, hourly dying to selfishness and pride.

FOUR COMPARTMENTS: HEBREW SANCTUARY

3. THE HOLY PLACE

- ❑ INSIDE—HOLY PLACE: EASTERN SIDE
- ❑ LEFT—THE SOUTH SIDE: SEVEN GOLDEN CANDLESTICKS CONTINUALLY BURNING
- ❑ LOOK RIGHT—TABLE OF SHOWBREAD —NORTH (**FRESH BREAD IS PROVIDED EVERY SABBATH BY THE PRIEST**) 12 CAKES—TWO PILES
- ❑ BREAD—CONTINUALLY



FOUR COMPARTMENTS: HEBREW SANCTUARY

THE HOLY PLACE PERSONAL APPLICATION

SEVEN GOLDEN CANDLESTICKS

- ❖ CHRIST HOLY OIL ENABLES US TO SHINE FORTH HIS LIGHT
- ❖ EVEN IF WE ARE MANY MEMBERS —YET WE ARE ONE BODY IN CHRIST
- ❖ CHRIST WANTS US TO STAND TALL AND BURN BRIGHT FOR HIM
- ❖ THE AMOUNT OF LIGHT WE RADIATE IS IN PROPORTION TO THE AMOUNT OF OIL WE RECEIVE
- ❖ OUR LAMPS MUST ALWAYS BE TRIMMED



WE SUPPORT UNITY IN THE FORM OF THE SEVEN GOLDEN CANDLESTICKS—NOT ECUMENISM

**Baha'i, Buddhism, Christianity, Confucianism, Hinduism, Islam, Jainism, Judaism, Shinto, Sikhism, Taoism,
Wicca, Zoroastrianism, and Druidism**



FOUR COMPARTMENTS: HEBREW SANCTUARY

THE HOLY PLACE MESSAGE OF THE SEVEN GOLDEN CANDLESTICKS

☐ SANCTIFICATION

- ☐ THE TALENT WEIGHED 75 POUNDS OF PURE GOLD:
- ☐ THE COST OF WITNESSING FOR CHRIST WILL BE VERY COSTLY AT TIMES
- ☐ PEOPLE WILL TURN AGAINST YOU: YOU MAY LOSE YOUR JOB—REPUTATION—LIFE—FAMILY—BROTHERS AND SISTERS IN CHRIST—HOME—POSSESSIONS—ETC
- ☐ THE LAMP WAS MADE OUT OF BEATEN GOLD—JESUS ENDURED MUCH SUFFERING THROUGH HIS CRUCIFIXION AS WE ARE TO ENDURE TOO...
- ☐ THE LAMP WAS ONE (UNITY) BUT IT HAD SEVEN BRANCHES—COMPLETENESS



FOUR COMPARTMENTS: HEBREW SANCTUARY

THE HOLY PLACE MESSAGE OF THE SEVEN GOLDEN CANDLESTICKS

- ❑ THE LAMP'S SOFT GLOW: THE LAMPSTAND HAD A HIGH STANDARD OF REACH AND A PURE BURN WITH A SOFT GLOW OF LIGHT (NOT DAZZLING BUT DEFINITION AND CONSISTENT SOFT GLOW)
 - ❑ THE LAMPSTAND WAS HIGH ON MORALS BUT MERCIFUL WITH THE ERRING ONES WHO STRAYED AWAY FROM THE TRUE LIGHT
 - ❑ THERE WERE 70 BOWLS & KNOPS— REPRESENTS THE 70 ELDERS OF ISRAELITES
- EXODUS 25:31-40
EXODUS 24:1, 9, 10
GENESIS 2:1-3 & 41:1-8



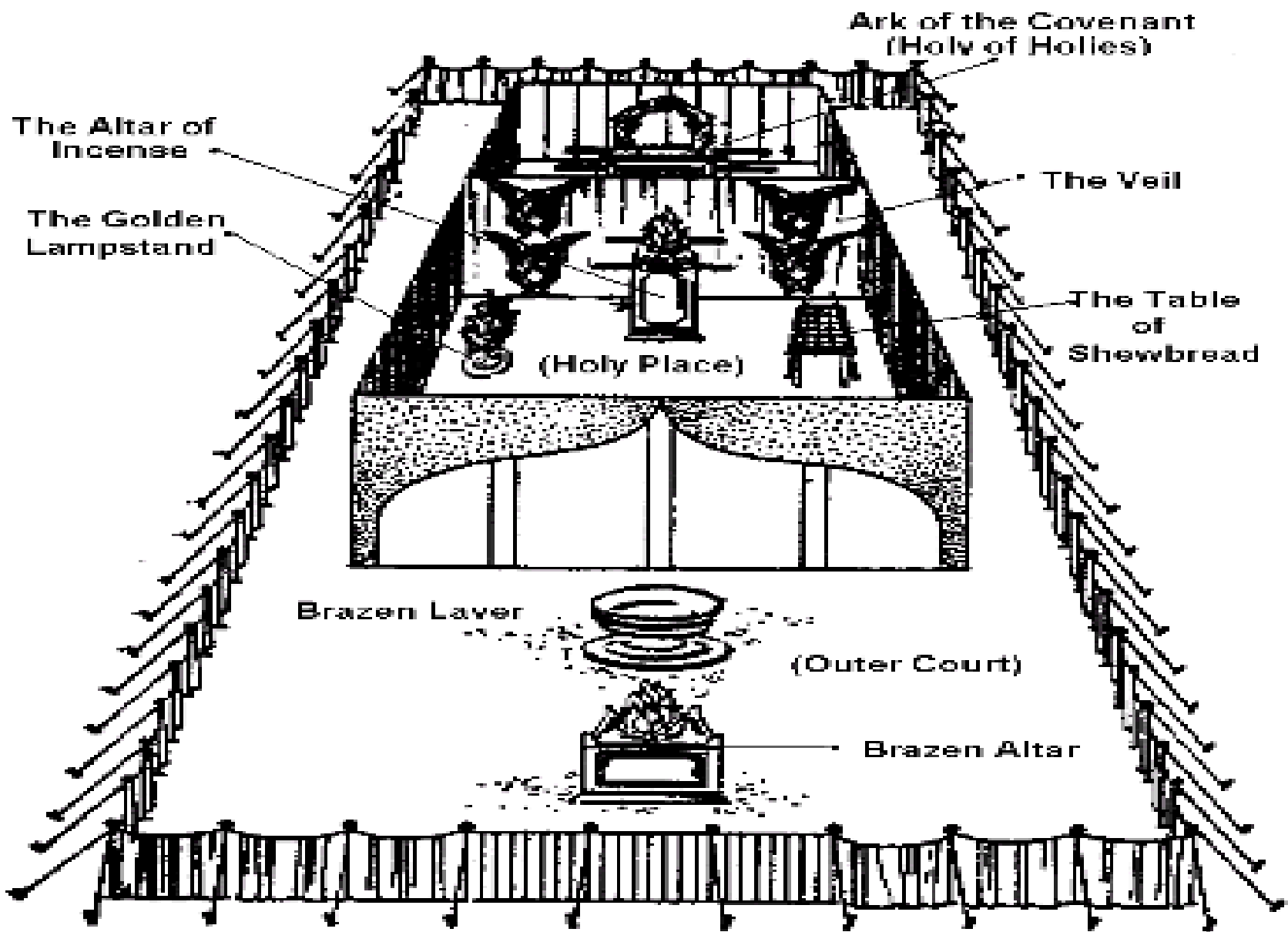

SEVEN GOLDEN CANDLESTICKS AND THE TABLE OF SHOWBREAD - TWO PILES



THE TABLE OF SHOWBREAD—TWO PILES

THE PERSONAL APPLICATION OF THE TABLE OF SHOWBREAD

- ❖ CHRIST' HUMANITY—ACACIA WOOD
AND HIS DIVINITY—GOLD
OVERLAY
 - ❖ GOD SUPPLIES PHYSICAL AND
SPIRITUAL NEEDS OF HIS PEOPLE
 - ❖ WE MUST CHEW—MASTICATE AND
MEDITATE UPON THE WORD OF GOD
 - ❖ THE SHOWBREAD WAS ACCOMPANIED
BY FRANKINCENSE
- LEVITICUS 24:5-9
- ❖ FRANKINCENSE SUGGESTED THE
FRAGRANCE OF JESUS' INTERCESSION ON
BEHALF OF HIS PEOPLE IS OF A SWEET
AROMA
 - ❖ EVERY SABBATH DAY—WE NEED A FRESH
AND SOLID WORD: NOT STALE BREAD—
BABY FORMULA

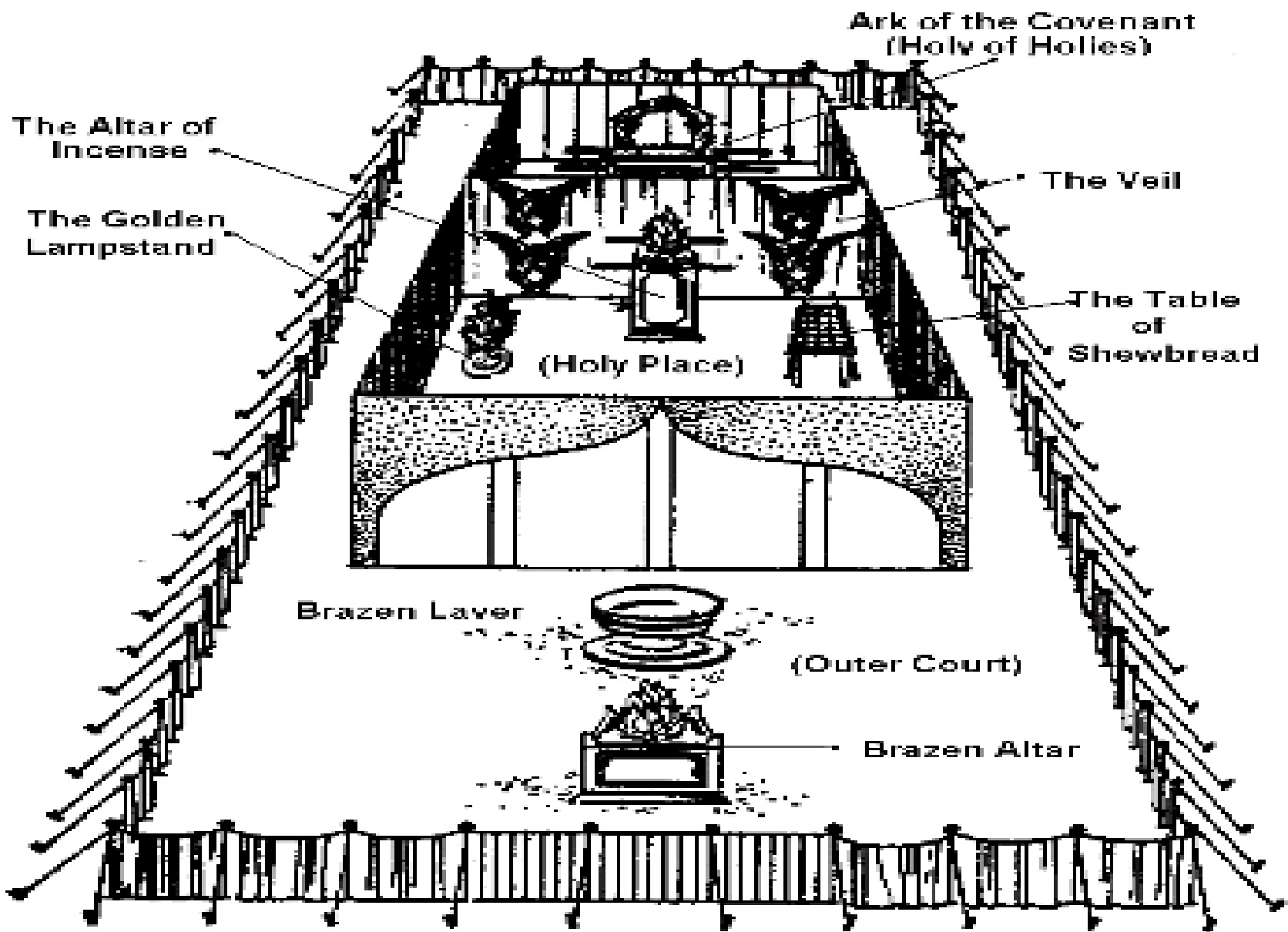

TABLE OF SHOWBREAD - TWO PILES

THE MESSAGE OF THE TABLE OF SHOWBREAD—NUTRITION

- ❖ IF CHRISTIANS DON'T FEAST ON GOD'S WORD—THEY'LL DIE SPIRITUALLY
- ❖ IF CHRISTIANS DON'T STUDY GOD'S WORD—THEY'LL BE WEAK AT OVERCOMING TEMPTATION
- ❖ BABIES IN CHRIST NEED THEIR BABY FORMULA—AND MATURED CHRISTIANS NEED SOLID FOOD
- ❖ CHRISTIANS MUST HAVE THEIR SPIRITUAL MEALS JUST AS THEY NEED THEIR REGULAR MEALS
- ❖ WHEN CHRISTIANS GO WITHOUT STUDYING GOD'S WORD—THEY ARE COMMITTING A SIN—AND ARE PUTTING THEMSELVES AT THE MERCY OF SATAN





FOUR COMPARTMENTS: HEBREW SANCTUARY

THE ALTAR OF INCENSE

THE SWEET-SMELLING AROMA FROM THE INCENSE WAS TO CONTINUALLY KEEP ON ASCENDING UP FROM THE HOLY PLACE INTO THE MOST HOLY PLACE

SO THE PRAYERS OF GOD'S PEOPLE MUST BE CONTINUALLY BE ASCENDING UP TO GOD—COUPLED WITH THE MERITS OF JESUS SO THEY CAN BE ACCEPTABLE UNTO GOD

PRAYERS ARE ASCENDING WHILE BLESSINGS ARE DESCENDING (FROM THE PRESENCE OF GOD ALMIGHTY)



FOUR COMPARTMENTS: HEBREW SANCTUARY

THE APPLICATION OF THE ALTAR OF INCENSE

- GOD WANTS US TO INTERCEDE CONTINUALLY FOR OTHERS
- OUR PRAYERS WILL BRING DOWN STRONGHOLDS AND WICKEDNESS IN HIGH PLACES
- GOD WANTS OUR PRAYERS TO BE SINCERE IN WORD AND IN DEED
- PRAYER IS THE ARTILLERY THAT SOFTENS UP THE ENEMY'S TERRITORY
- JUST AS THE ALTAR OF INCENSE STANDS IN FRONT OF THE MERCY SEAT—SO SHOULD WE STAND RESOLUTE BEFORE GOD SEEKING HIS MERCY ON BEHALF OF UNGODLY ONES
- GOD ONLY ACCEPTS PRAYERS WHICH COME FROM PERSONS WILLING TO CHANGE



FOUR COMPARTMENTS: HEBREW SANCTUARY

THE MESSAGE OF THE ALTAR OF INCENSE—INTERCESSION

- EXODUS 30:1-10 COMPARED WITH REVELATION 19:12—JESUS IS DESCRIBED AS WEARING A CROWN
- THE CROWNS AROUND THE TABLE-ALTAR-ARK ARE TYPES OF THE VICTORIES PROMISED TO GOD'S PEOPLE THROUGH THE MERITS OF JESUS
- GOD WILL NOT TOLERATE COMMON OR STRANGE FIRE—LEVITICUS 10:1, 2 (NADAB & ABIHU)
- GOD WILL NOT TOLERATE UNSANCTIFIED WORSHIP COMING FROM SANCTIFIED INSTRUMENTS AND VESSELS
- GOD WILL HEAR AND ATTEND TO OUR NEEDS—NOT OUR GREEDS



LOOK STRAIGHT AHEAD - HOLY PLACE: ALTAR OF INCENSE

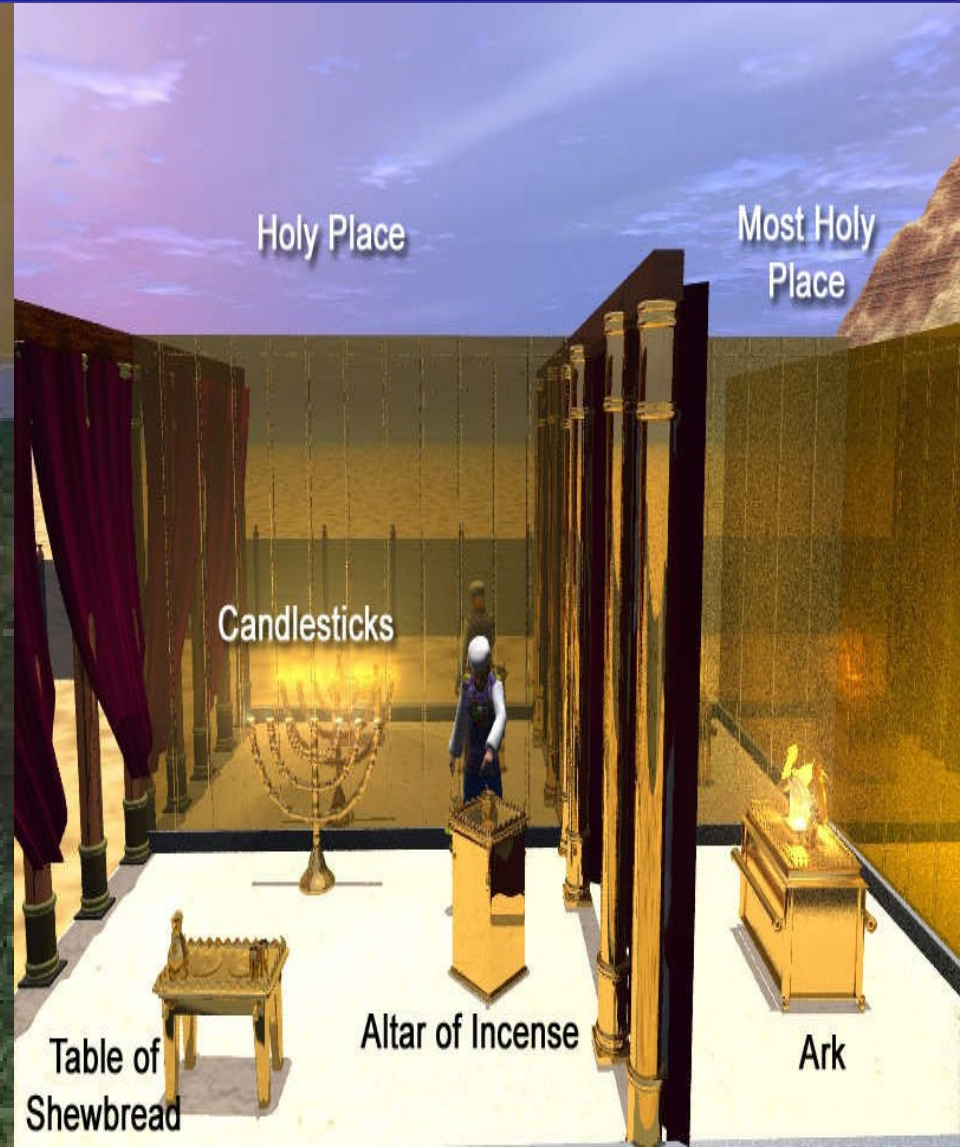

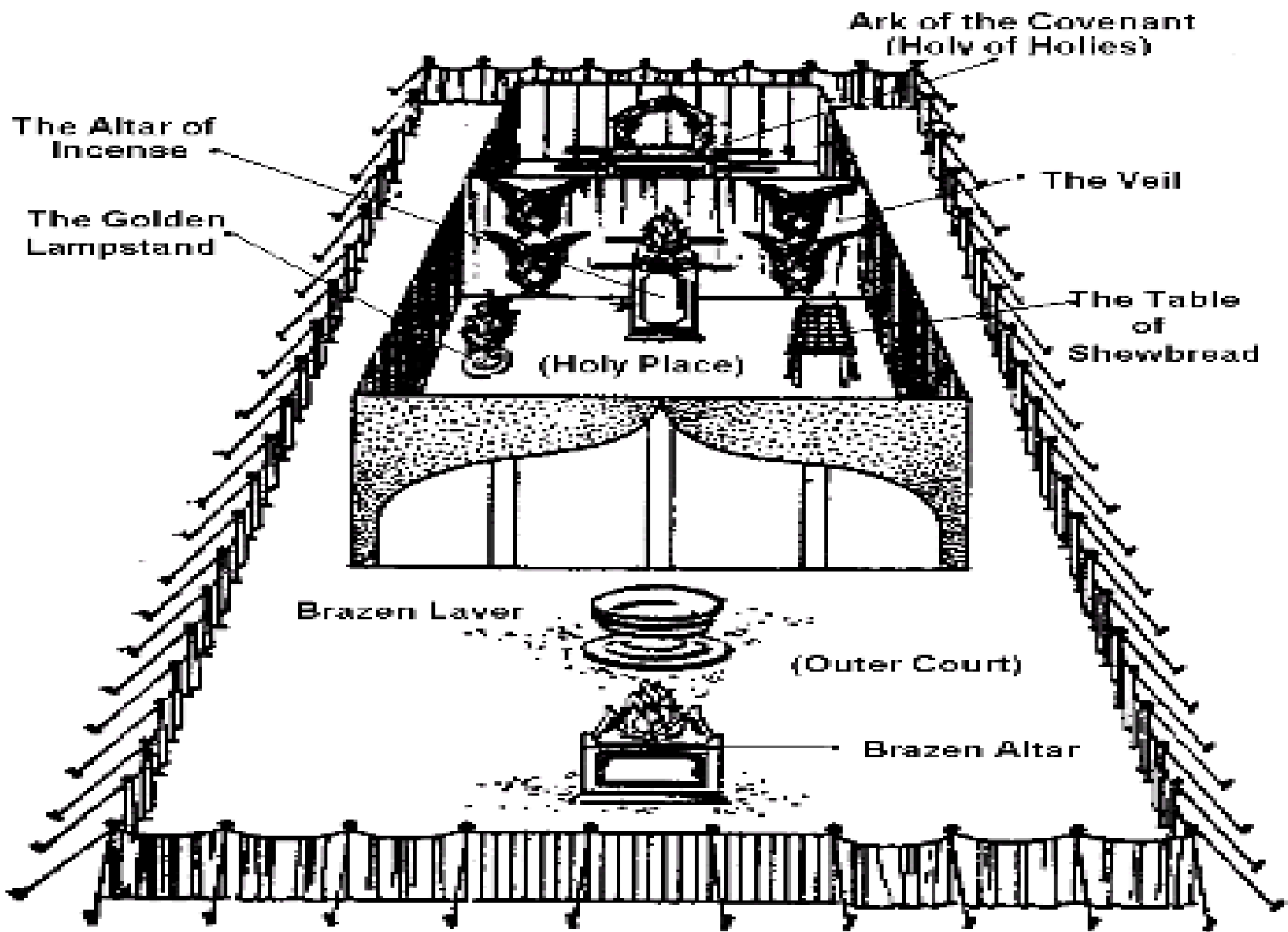

FOUR COMPARTMENTS: HEBREW SANCTUARY

4. THE ARK OF THE COVENANT
- ❖ INSIDE: AARON'S ROD—BUDDING
 - ❖ POT OF MANNNA
 - ❖ THE LAW—TEN COMMANDMENTS
 - ❖ ABOVE THE ARK: MERCY SEAT (TWO CHERUBIMS)
 - ❖ SHEKINAH GLORY
 - ❖ GOD—NOT THE ARK—IS TO BE REVERED
 - ❖ THE ARK OF THE COVENANT—HOLINESS
 - ❖ SINNERS CANNOT LIVE IN THE MIDST OF A HOLY GOD—SANCTIFIED



FOUR COMPARTMENTS: HEBREW SANCTUARY

THE APPLICATION OF THE ARK OF THE COVENANT

- ❖ GOD WANTS TO COVENANT WITH US—(PEOPLE)
- ❖ ANGELS ARE ALWAYS WATCHING & PROTECTING
- ❖ HIS SHEKINAH LIGHT IN US WILL LET OTHERS BEHOLD HIS GLORY
- ❖ AT THE FOUNDATION OF HIS GOVT. AND COVENANT IS HIS LAW
- ❖ HIS COVENANT MUST BE CARRIED WHEREVER HIS PEOPLE GO
- ❖ GOD'S LAW IS IMMOVABLE AND UNCHANGEABLE
- ❖ GOD DISPLAYS HIS COVENANT ATTRIBUTES: BUT HE WILL NEVER ACCEPT SECOND PLACE AND ANOTHER MUTINEE FROM A DISOBEDIENT PERSON (S)



FOUR COMPARTMENTS: HEBREW SANCTUARY

THE MESSAGE OF THE ARK OF THE COVENANT—GLORIFICATION

- ❖ ALL SOURCE OF ALL LIGHT COMES FROM GOD
- ❖ HE IS THE PILLAR OF FIRE THAT LED THE ISRAELITES
EXODUS 14:24
- ❖ SIN IS IMMEDIATELY CONSUMED IN GOD'S PRESENCE
- ❖ THE VEIL (A SERIES OF DOORS) REPRESENTS JESUS—THE ONLY DOOR TO GLORIOUS LIFE
- ❖ PLACEMENT OF THE SANCTUARY FURNITURES IS GOD'S PROGRESSIVE PATH LEADING FROM THE COURTYARD TO THE MOST HOLY PLACE
- ❖ COVENANT WITH GOD BEGINS WITH OUR BAPTISM



HEBREW SANCTUARY: THE ARK OF THE COVENANT



INSIDE THE ARK OF THE COVENANT: THE LAW—TEN COMMANDMENTS



INSIDE THE ARK OF THE COVENANT: THE LAW—TEN COMMANDMENTS



INSIDE THE ARK OF THE COVENANT: THE LAW—TEN COMMANDMENTS

THOU SHALT HAVE NO
OTHER GODS BEFORE ME

THOU SHALT NOT MAKE
UNTO THEE ANY GRAVEN
IMAGE OR ANY LIKENESS
OF ANY THING

THOU SHALT NOT TAKE
THE NAME OF THE LORD
THY GOD IN VAIN

REMEMBER THE SABBATH
DAY TO KEEP IT HOLY SIX
DAYS SHALT THOU LABOR
AND DO ALL THY WORK BUT
THE SEVENTH DAY IS THE
SABBATH OF THE LORD

HONOR THY FATHER AND
THY MOTHER

THOU SHALT NOT KILL

THOU SHALT NOT COMMIT
ADULTERY

THOU SHALT NOT STEAL

THOU SHALT NOT BEAR
FALSE WITNESS AGAINST
THY NEIGHBOR

THOU SHALT NOT COM

INSIDE THE ARK OF THE COVENANT: THE LAW—TEN COMMANDMENTS

THOU SHALT HAVE NO
OTHER GODS BEFORE ME

THOU SHALT NOT MAKE
UNTO THEE ANY GRAVEN
IMAGE OR ANY LIKENESS
OF ANY THING

THOU SHALT NOT TAKE
THE NAME OF THE LORD
THY GOD IN VAIN

REMEMBER THE SABBATH
DAY TO KEEP IT HOLY SIX
DAYS SHALT THOU LABOR
AND DO ALL THY WORK BUT
SEVENTH DAY IS THE

HONOR THY FATHER AND
THY MOTHER

THOU SHALT NOT KILL

THOU SHALT NOT COMMIT
ADULTERY

THOU SHALT NOT STEAL

THOU SHALT NOT BEAR
FALSE WITNESS AGAINST
THY NEIGHBOR

THOU SHALT NOT COVET

OUTSIDE: LAW OF CEREMONIES OR ORDINANCES OF MOSES—WRITTEN UPON A SCROLL OR IN A BOOK



OUTSIDE: LAW OF CEREMONIES OR ORDINANCES OF MOSES—WRITTEN UPON A SCROLL OR IN A BOOK



ABOVE THE ARK OF THE COVENANT: CHERUBIMS & SHEKINAH GLORY



DAILY TRANSACTIONS: COURTYARD

COURTYARD

SACRIFICIES OF CLEAN
ANIMALS WERE A DAILY
THING WHICH WAS DONE
ON BEHALF OF THE
SINNER



The Offerings

Only certain clean animals could be used for an offering.
The characteristics and the type of animal represented
what would happen to Christ when He died for our sins.
Leviticus 11

Characteristics of the Clean Animals.

Rules for Clean Animals

Ruminant

Stomach

Creature

Clean Use—Christ (No fermentation—No sin—No decay—No uncleanness)

Unclean animals and scavengers cannot represent Christ, because they take life and drink blood, and they cannot demonstrate the wounds on the body of Christ.



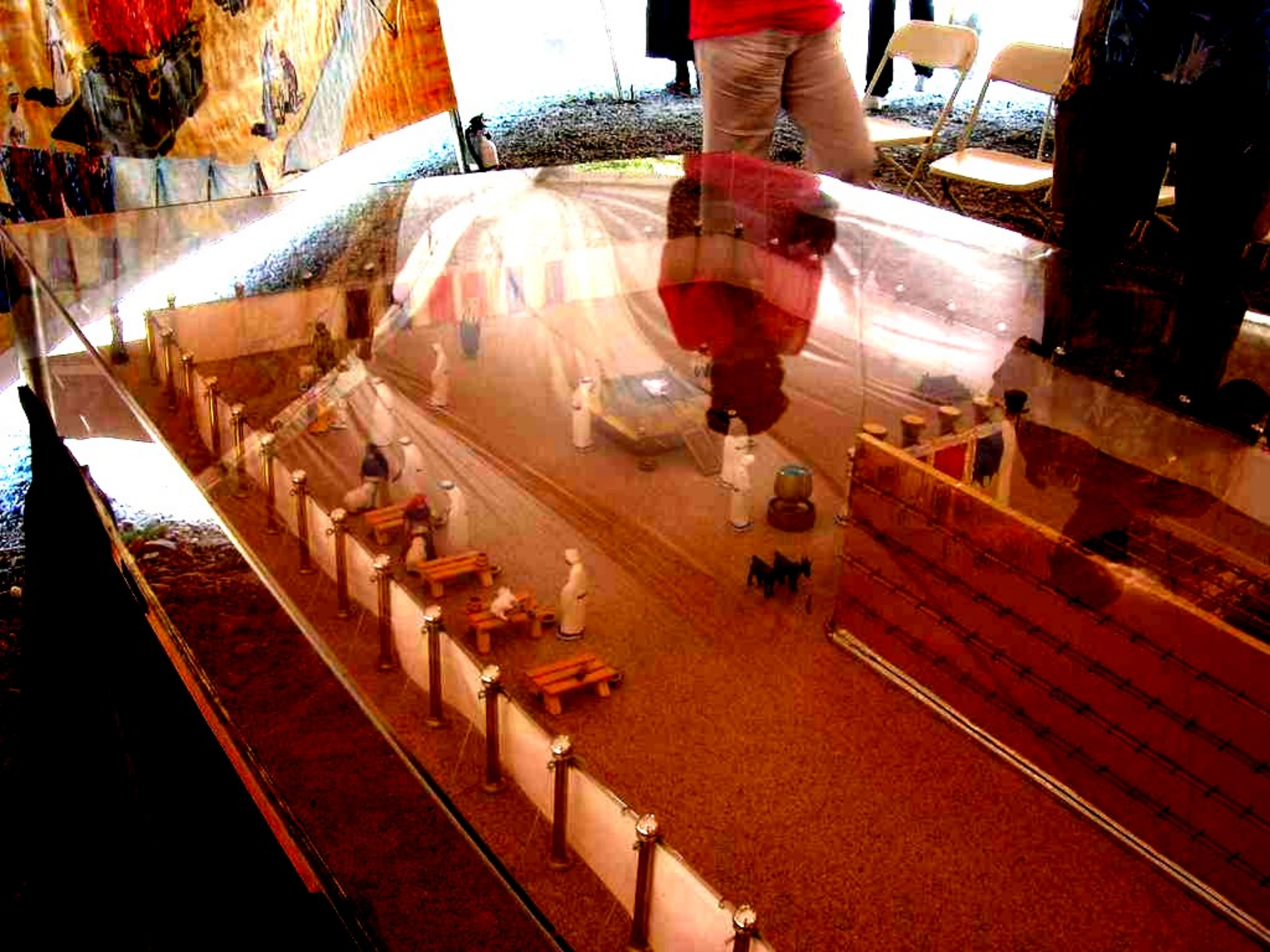





DAILY TRANSACTIONS: HOLY PLACE

HOLY PLACE

- SEVEN GOLDEN CANDLESTICKS— CONTINUALLY BURNING IN THE SANCTUARY
- INCENSE (SWEET-SMELLING AROMA) WAS CONTINUALLY ASCENDING UP TO HEAVEN (DAY & NIGHT)
- THE SHOWBREAD—FRESH BREAD —ONCE EVERY WEEK (SABBATH)

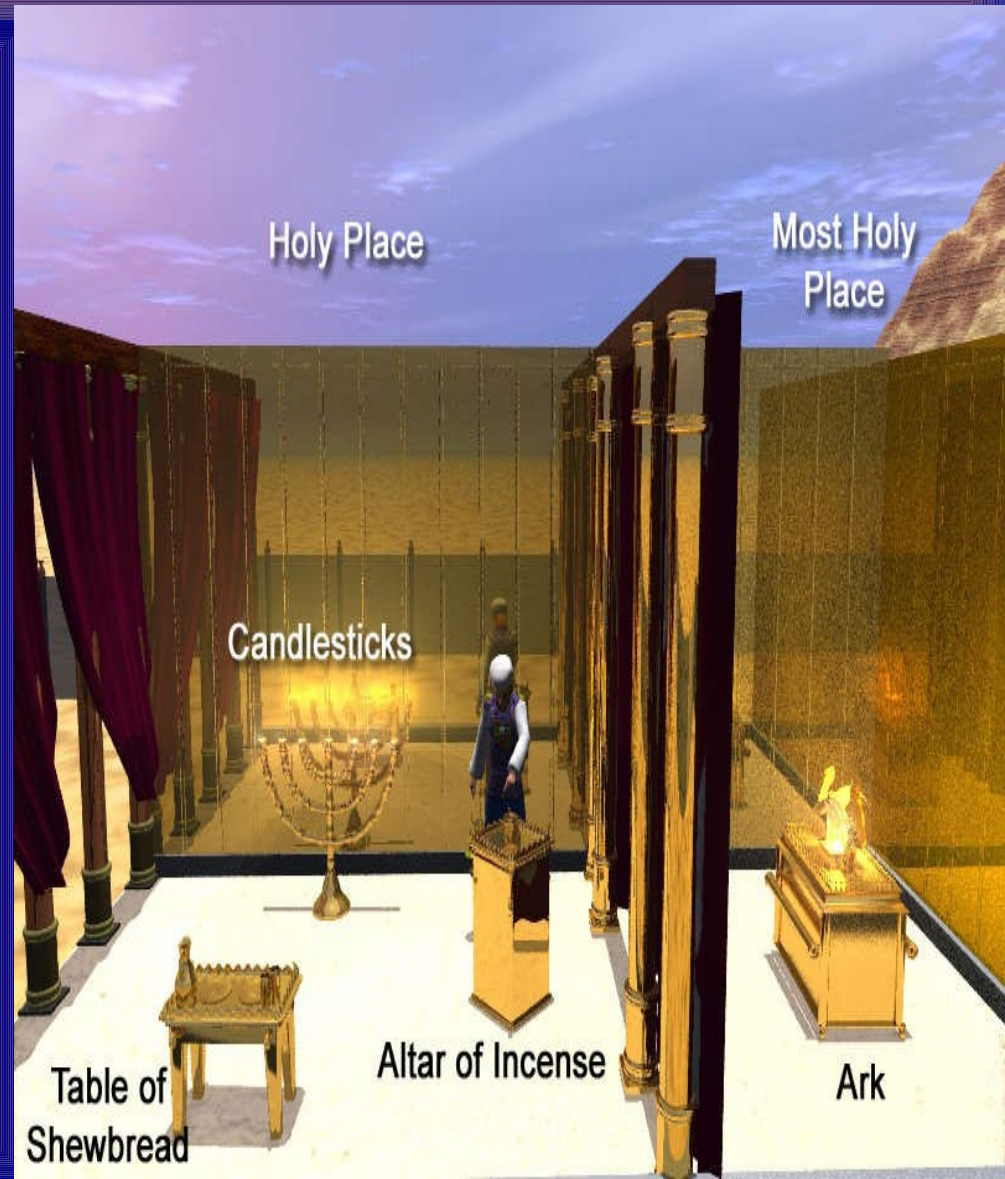





YEARLY TRANSACTIONS: THE MOST HOLY PLACE

THE MOST HOLY PLACE

THE DAY OF

AT-ONE-MENT (THE GREAT DAY OF JUDGMENT) FOR ISRAEL DURING THAT TIME

THE FEAST OF TRUMPETS (THAT ANNOUNCED THAT GREAT DAY OF ATONEMENT WAS NEAR

THE HIGH PRIEST (AT THAT TIME) WAS TO BE IN THE MOST HOLY PLACE OF THE SANCTUARY PERFORMING THE YEARLY ATONEMENT ON BEHALF OF THE PEOPLE AND HIMSELF



**A VIRTUALLY LIVE EXHIBIT & TOUR—SANCTUARY
POINT AND CLICK IN THE MIDDLE OF THE BLACK BOX TO SEE
VIDEO CLIP**

THE HEBREW & HEAVENLY SANCTUARY SERVICES—COMMON

SERVICES—HOLY PLACE & MOST HOLY PLACE

N:B: THEY REPRESENT TWO IMPORTANT ASPECTS

**6. SERVICES IN THE HOLY AND THE MOST HOLY PLACE
REPRESENT DIFFERENT ASPECTS OF CHRIST' WORK**

**8. VARIOUS COMPARTMENTS OF THE HEBREW SANCTUARY
DEPICT VARIOUS FUNCTIONS OF CHRIST IN THE PLAN OF
SALVATION**

LITERAL & SYMBOLICAL MEANING OF CHRIST: 2 CORINTHIANS 5:20, 21

❖ COURTYARD AND THE HEBREW PRIEST

3. CLEAN ANIMALS WERE
SACRIFICED

4. THESE ANIMALS HAD TO BE
WITHOUT SPOT OR
WRINKLE

5. THEY HAD TO BE HEALTHY
ANIMALS

6. THESE ANIMALS WERE TO
SYMBOLICALLY BEAR THE
SINS OF THE REPENTANT
SINNER

❖ COURTYARD AND THE HEAVENLY PRIEST

3. CHRIST WAS SACRIFICED FOR
US

4. CHRIST WAS THE LAMB WHO
WAS WITHOUT-SPOT OR
WRINKLE

5. CHRIST HAD TO BE HEALTHY
MAN (YOUNG AND STRONG-
YOUTH)

6. CHRIST LITERALLY AND
SYMBOLICALLY BORE THE
SINS OF EVERY REPENTANT
SINNER

LITERAL & SYMBOLICAL MEANING - CHRIST

❖ COURTYARD

4. ALTAR OF LAVER

THE PRIEST WAS TO WASH AND
CLEANSE HIS HANDS
BEFORE ENTERING INTO THE
HOLY PLACE

2. MINI BAPTISM

REPRESENTS CLEAN HANDS
AND HEARTS

❖ COURTYARD

4. CHRIST WASHES OUR SINS AWAY—BAPTISM

REVELATION 1:5

REVELATION 19:7-9

2. CHRIST CLEANSSES US FROM ALL OUR INIQUITIES

REVELATION 1:5



COURTYARD SACRIFICE: LITERAL & SYMBOLIC

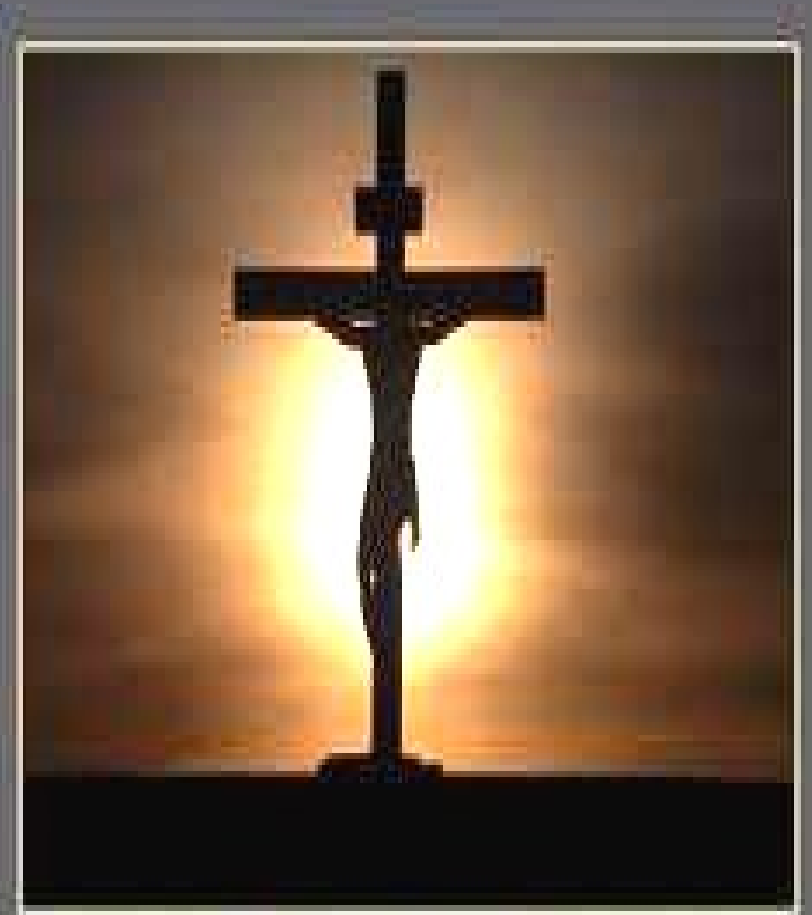
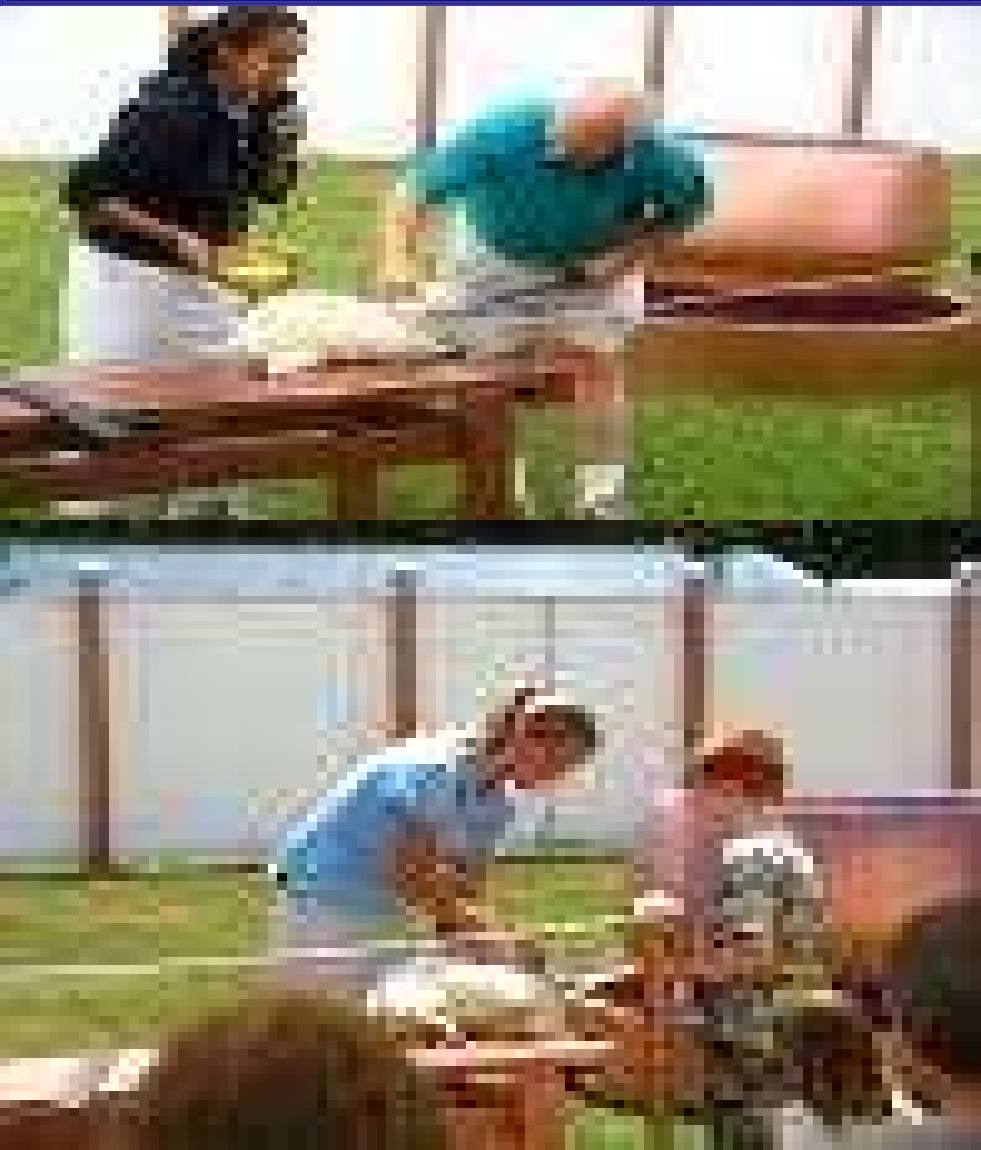

The Lamb of God



LITERAL & SYMBOLICAL MEANING - CHRIST

❖ THE HOLY PLACE

2. SEVEN CANDLESTICKS CONTINUALLY BURNING
3. THE TABLE OF SHOWBREAD (12 CAKES IN TWO PILES) WAS TO BE CONTINUALLY PRESENT AND FRESH—LIVING WORD
4. THE ALTAR OF INCENSE HAD TO BE CONTINUALLY BURNING. IT REPRESENTED THE PRAYERS OF THE SAINTS MIXED WITH THE MERITS OF CHRIST TO BE ACCEPTABLE UNTO GOD

❖ THE HOLY PLACE

- ❖ CHRIST IS THE ONLY TRUE LIGHT OF THE WORLD
- ❖ CHRIST (GOD IN THE FLESH) IS THE BREAD OF LIFE—LIVING BREAD (WORD) THAT SATISFIES ALL OUR CRAVINGS
- ❖ CHRIST LEFT EARTH AND WENT TO HEAVEN—HOLY PLACE:
- E. ILLUMINATION—SEVEN GOLDEN CANDLESTICKS
- F. NUTRITION—SHOWBREAD
- G. INTERCESSION—ALTAR OF INCENSE

LITERAL & SYMBOLIC MEANING - CHRIST



LITERAL & SYMBOLICAL MEANING - CHRIST

❖ THE MOST HOLY PLACE

2. THE ARK OF THE COVENANT
(THE COVENANT-HOUSED)

2. THE CHERUBIMS (GOD'S SHEKINAH
GLORY) KEEPING A CONSTANT WATCH

8. THE LAW-TEN COMMANDMENTS
(ROCK SOLID REQUIREMENTS)
 - A. AARON'S ROD BUDDING
NUMBERS 17

 - P. THE POT OF MANNER

❖ THE MOST HOLY PLACE

2. CHRIST IS JUDGING THE DEAD AND THE
LIVING ACCORDING TO THEIR WORKS—
HIS HOLY LAW

3. HIS MESSENGERS—ANGELS ARE
BRINGING EVERY WORD OR WORK INTO
JUDGMENT... WHETHER THEY ARE DONE
IN SECRET OR IN THE OPEN. WHETHER
THEY BE WITH ILL-WILL OR GOOD-WILL

4. HIS LAW—TEN COMMANDMENTS
PROJECT THE SUPREME STANDARD
OF GOD'S RIGHTEOUSNESS
 - E. AARON'S ROD BUDDING
MIGHTY ACTS—DIVINE AUTHORITY OF GOD
SHOULD NEVER BE QUESTIONED AGAIN
THROUGH THE ELECTION OF HIS
LEADERS

 - B. GOD'S SEED (TRUE CHURCH) WILL
NEVER BEG BREAD

**WHAT HAPPENS WHEN JESUS
CEASES HIS INTERCESSORY AND
MEDIATORIAL WORK?**

**AT SOME POINT IN TIME, JESUS CHANGES FROM HIS
PRIESTLY ROBE INTO HIS KINGLY ROBE—AND PREPARES
TO RETURN AS KING OF KINGS AND LORD OF LORDS.
HEBREWS 3:1-11 & REVELATION 19:14-16**

REVELATION'S PATTERN OF CHRIST (HIGH PRIEST) IN THE HEBREW SANCTUARY

REVELATION 1:5

And from Jesus Christ, [who is] the faithful witness, [and] the first begotten of the dead, and the prince of the kings of the earth. Unto him that loved us, and washed us from our sins in his own blood,...

STUDY:

REVELATION CHAPTERS 1-3

QUESTIONS THAT NEED ANSWERS

- **WHAT FURNITURES ARE ASSOCIATED WITH THIS TEXT?**
- **WHAT COMPARTMENT OF THE HEBREW SANCTUARY IS THIS TEXT MAKING REFERENCE TO?**
- **AND WHO IS THIS FAITHFUL WITNESS WHO LOVED AND WASHED US IN HIS BLOOD WITH REGARD TO REVELATION 1:5?**

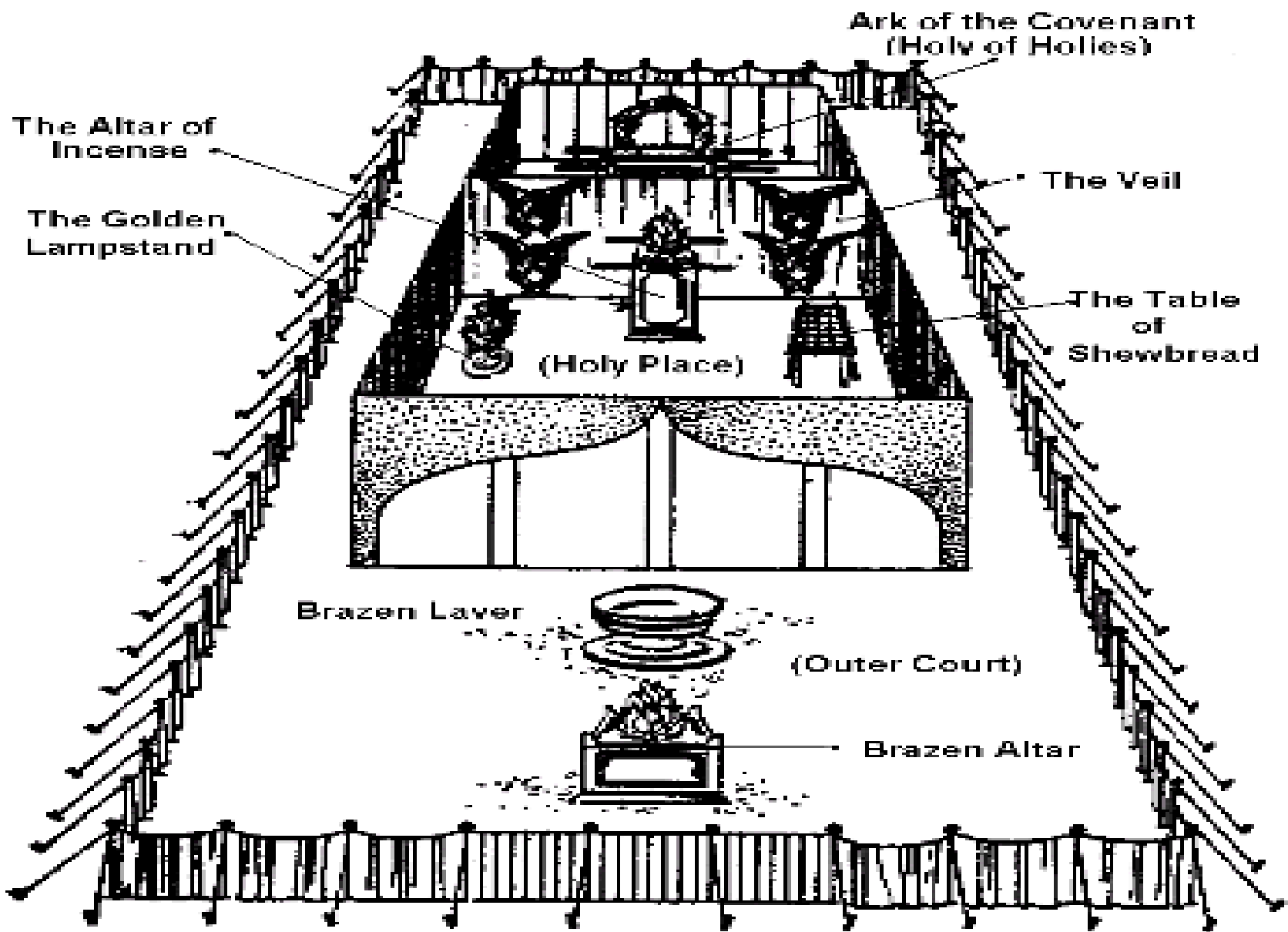

REVELATION'S PATTERN OF CHRIST IN THE HEBREW SANCTUARY THE COURTYARD



REVELATION'S PATTERN OF CHRIST AMIDST THE HEBREW SANCTUARY

REVELATION 1:12, 13

And I turned to see the voice that spake with me. And being turned, I saw seven golden candlesticks; And in the midst of the seven candlesticks [one] like unto the Son of man, clothed with a garment down to the foot, and girt about the paps with a golden girdle.

QUESTIONS THAT NEED ANSWERS

- WHAT PIECE OF FURNITURE IS ASSOCIATED WITH THIS TEXT?
- WHAT COMPARTMENT OF THE HEBREW SANCTUARY IS THIS TEXT MAKING REFERENCE TO?
- AND WHO IS IN THE MIDST OF THE SEVEN GOLDEN CANDLESTICKS ACCORDING TO THIS TEXT?

REVELATION N'S PATTERN OF CHRIST AMIDST THE HEBREW SANCTUARY



REVELATION'S PATTERN OF CHRIST AMIDST THE HEBREW SANCTUARY

QUESTIONS THAT NEED ANSWERS

4. WHY SEVEN GOLDEN
CANDLESTICKS?

5. WHAT IS THE SON OF MAN
DOING IN THE MIDST OF
THE SEVEN GOLDEN
CANDLESTICKS WITH
REGARD TO THE HEBREW
SANCTUARY?

ANSWERS TO THESE QUESTIONS

- SEVEN REPRESENTS THE
HISTORICAL APOSTOLIC
COMPLETENESS OF THE CHURCH
AGE—FROM BEGINNING TO END

- WITH REGARD TO THE
CANDLESTICKS IN

LEVITICUS 24:1-4—THE HIGH PRIEST
HAD TWO FUNCTIONS:

E. HE WAS TO TRIM THE LAMPS—
WICKS TO KEEP THEM
CONTINUALLY BURNING BRIGHTLY

F. HE WAS TO ENSURE THAT THE
LAMPS HAD ENOUGH OF OIL TO
PREVENT THEM FROM GOING OUT

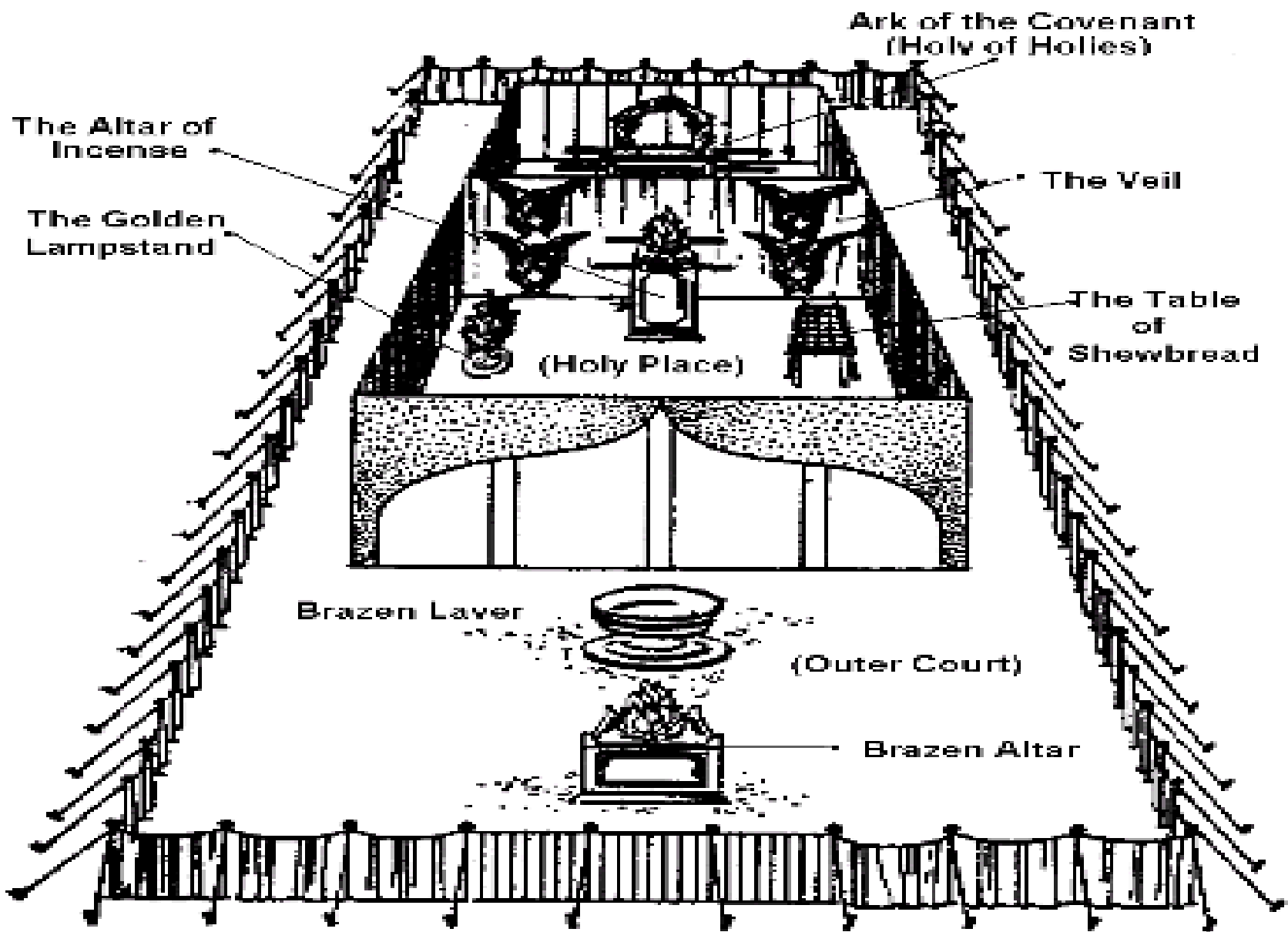

REVELATION'S PATTERN OF CHRIST AMIDST THE HEBREW SANCTUARY THE HOLY PLACE





WHY IS JESUS WALKING AMONG THE CANDLESTICKS WITH REGARD TO LEVITICUS 24:1-4?

SEVERAL REASONS

- JESUS WANTS TO ENSURE THAT THE LIGHT OF THE CHURCH DOES NOT GO OUT
- JESUS WANTS TO ENSURE THAT THE LIGHT OF THE CHURCH DOES NOT GROW DIM

CASE IN POINT: THE DARK AGES (CHURCH PERSECUTION)

- H. THE WORD OF GOD WAS SCARCE—IT FLICKED BUT IT NEVER WENT OUT
- I. PERSECUTION OF THE WALDENSES—THE WORD WAS TO BE PREACHED UNDER TRYING CIRCUMSTANCES
- J. THE CHURCH GAVE LIGHT—DURING THE DARK AGES—THE LIGHT WAS DIM—BUT IT NEVER WENT OUT!
- D. BIBLES—EVEN THOUGH THE WORD OF GOD WAS PRINTED IN LATIN—BUT THERE WAS ALWAYS A SUPPLY OF THE WORD OF GOD THAT WAS AVAILABLE IN THE LANGUAGE OF THE PEOPLE DURING THE DARK AGES

SPIRIT OF PROPHECY: REVIEW AND HERALD FEBRUARY 12, 1880

Let the history of the Waldenses testify what they suffered for their religion. Though persecuted and driven from their homes, they conscientiously studied the word of God, and lived up to the light which shone upon them. When their possessions were taken from them, and their houses burned, they fled to the mountains, and there endured hunger, fatigue, cold, and nakedness. And yet the scattered and homeless ones would assemble to unite their voices in singing and praising God, that they were accounted worthy to suffer for Christ's name. They encouraged and cheered one another, and were grateful for even their miserable retreat. Many of their children sickened and died through exposure to cold, and the sufferings of hunger; yet the parents did not for a moment think of yielding their faith. They prized the love and favor of God far more than earthly ease or worldly riches.

REVELATION'S PATTERN OF CHRIST AMIDST THE HEBREW SANCTUARY THE HOLY PLACE

TWO THRONES—TABLE OF SHOWBREAD SEVERAL REASONS

- GEOGRAPHICALLY—THAT WHICH WAS BEFORE THE SEVEN GOLDEN CANDLESTICKS WAS THE TABLE OF SHOWBREAD
- THE TABLE OF SHOWBREAD WAS IN THE NORTH AND THE SEVEN GOLDEN CANDLESTICKS WAS IN THE SOUTH (STUDY: REVELATIONS CHAPTERS 4-5)
- THE TABLE OF SHOWBREAD WAS THE ONLY FURNITURE THAT HAD CROWNS OF GOLD ALL AROUND IT

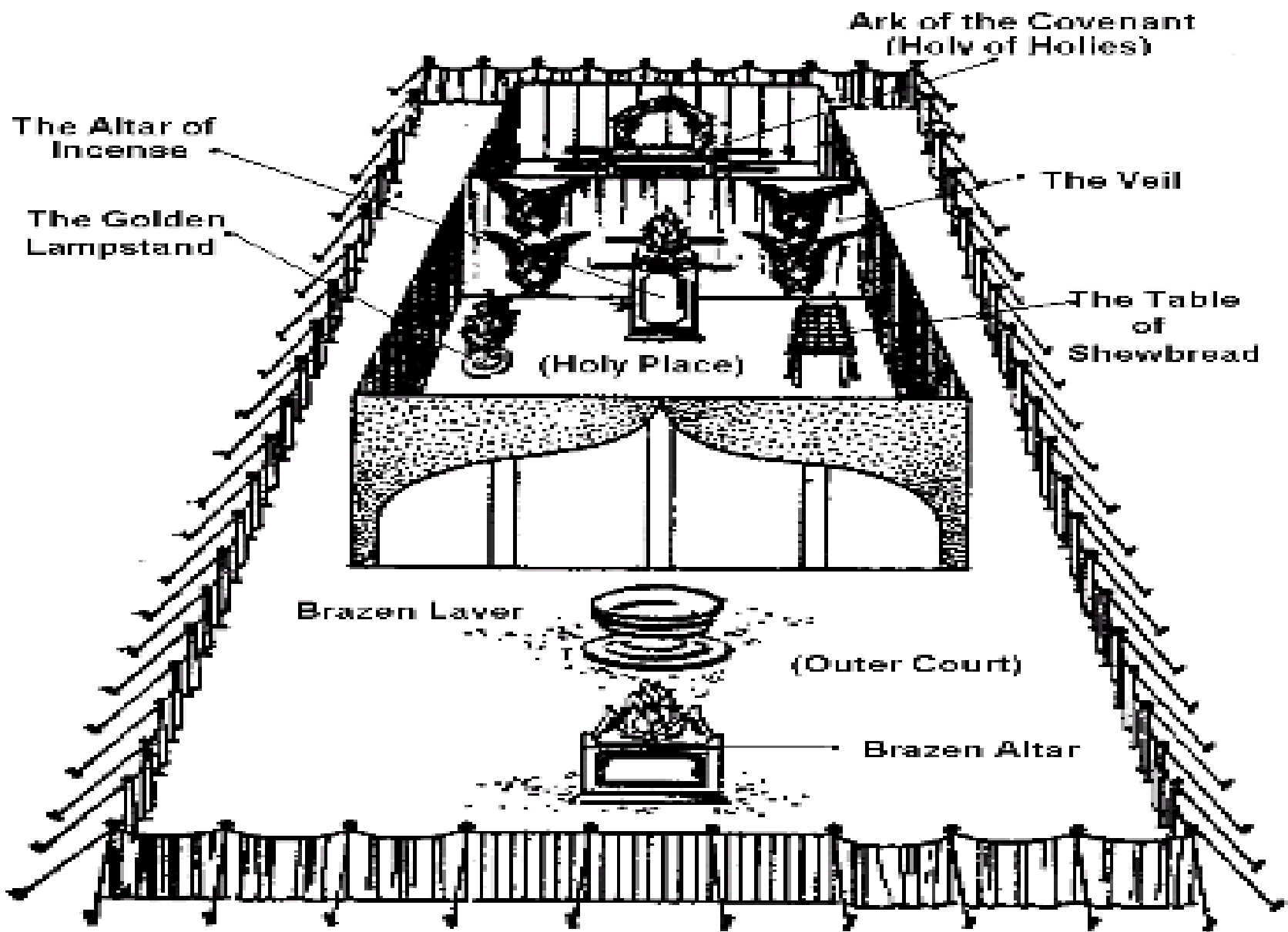



REVELATION'S PATTERN OF CHRIST AMIDST THE HEBREW SANCTUARY THE HOLY PLACE

TWO THRONES—TABLE OF SHOWBREAD QUESTIONS THAT NEED ANSWERS

4. WHO AMONG WORLD LEADERS USES CROWNS?

**N:B: THE TABLE OF SHOWBREAD HAD 12 CAKES DISTRIBUTED
INTO TWO PILES OF SIX**

5. IN REVELATION 3:21—WHAT COMPARTMENT DID JESUS
ASCENDED UP INTO AFTER HIS ASCENSION TO HEAVEN?

6. HOW MANY THRONES DOES THE BIBLE RECORD IN
REVELATION 3:21?

REVELATION'S PATTERN OF CHRIST AMIDST THE HEBREW SANCTUARY THE HOLY PLACE

TWO THRONES—TABLE OF SHOWBREAD

QUESTION THAT NEED ANSWERS

7. WHO WANTED TO ASCEND INTO THE NORTH TO USURP GOD'S
THRONE?

(READ ISAIAH 14:12-14)

8. UPON JESUS' ASCENSION INTO HEAVEN—WAS HE CROWNED
AS THE INTERCESSOR OF GRACE—AND WHERE (IN WHICH
COMPARTMENT)?

9. WERE BOTH (JESUS & GOD) A SOURCE OF BREAD FOR GOD'S
PEOPLE? (JOHN 14:1-3 & JOHN 6:32-35)

REVELATION'S PATTERN OF CHRIST AMIDST THE HEBREW SANCTUARY THE HOLY PLACE

QUESTIONS THAT NEED ANSWERS

N:B:...It is written, Man shall not live by bread alone, but by every word that proceedeth out of the mouth of God. MATTHEW 4:4

10. UNDER THE THIRD SEAL— WAS THERE A SCARCITY OF WHEAT AND BARLEY? (READ REVELATION 6:6)
11. UNDER THE PERIOD OF THE THIRD SEAL (DURING THE TIME OF CONSTANTINE—ROME) FALSE DOCTRINES ENTERED THE CHURCH— HENCE WHEAT AND BARLEY (WHICH WAS USED TO MAKE BREAD AND WERE SYMBOLIC OF THE WORD OF GOD) WAS SCARCE AND BECAME EXPENSIVE.
12. WERE PEOPLES' LIVES AT STAKE DURING THAT TIME?

REVELATION'S PATTERN OF CHRIST AMIDST THE HEBREW SANCTUARY THE HOLY PLACE

TWO THRONES—TABLE OF SHOWBREAD
LEVITICUS 24:1-4—REVELATION 6:6—REVELATION 11

- JESUS (SYMBOLICALLY) IS LOCATED AT THE TABLE OF SHOWBREAD FEEDING HIS PEOPLE
- WERE THERE PERIODS DURING THE DARK AGES WHEN THE BREAD (WORD OF GOD) WAS SCARCE?
- WERE THERE PERIODS IN THE CHURCHES' HISTORY WHEN GOD'S PEOPLE WERE AT THE POINT OF STARVATION?
- ALTHOUGH THE BIBLE WAS CHAINED-BURNED-AND TAKEN AWAY FROM THE PEOPLE—DID THE BREAD EVER RAN OUT?

REVELATION'S PATTERN OF CHRIST AMIDST THE HEBREW SANCTUARY THE HOLY PLACE



REVELATION'S PATTERN OF CHRIST AMIDST THE HEBREW SANCTUARY THE HOLY PLACE



**JESUS IS WALKING IN THE MIDST OF THE
SEVEN GOLDEN CANDLESTICKS AND
AMONG THE TABLE OF SHOWBREAD - IS
INDICATIVE OF HIM DOING WHAT?**

- **HE'S GIVING LIGHT TO HIS CHURCH CONTINUALLY IN
PERIODS OF OBSCURITY**
- **HE'S FEEDING HIS CHURCH CONTINUALLY IN PERIODS OF
SCARCITY**
- **WHAT PARALLEL OF ASSURANCE IS THERE FOR GOD'S
PEOPLE AFTER THE CLOSING OF THE MOST HOLY PLACE—
PRIOR AND DURING THE FALLING OF THE SEVEN LAST
PLAGUES?**

READ—PSALMS 23

Thy word [is] a lamp unto my feet, and a light
unto my path. PSALMS 119:105



REVELATION'S PATTERN OF CHRIST AMIDST THE HEBREW SANCTUARY THE HOLY PLACE



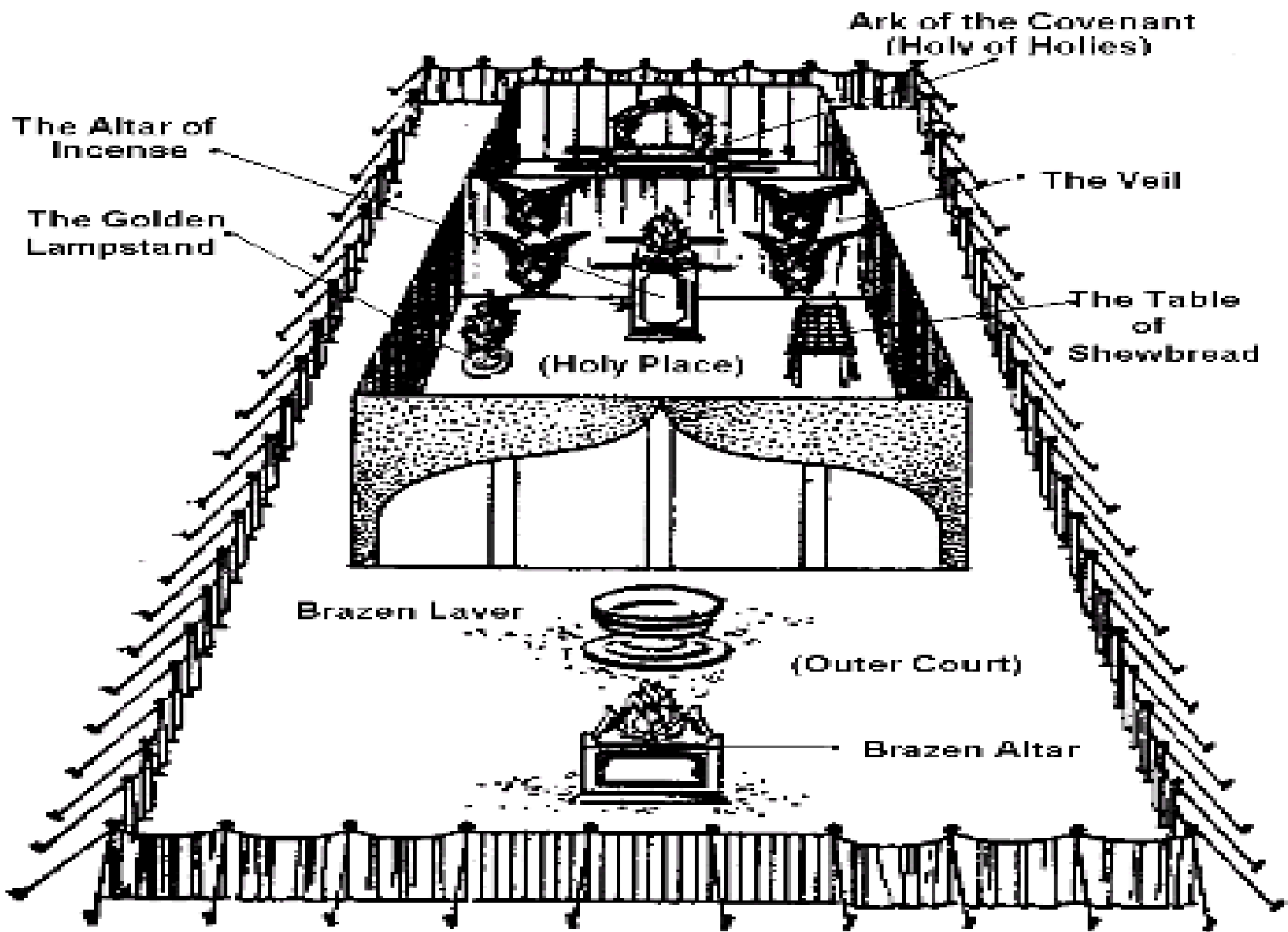

REVELATION'S PATTERN OF CHRIST AMIDST THE HEBREW SANCTUARY THE HOLY PLACE

REVELATION 8:3, 4

And another angel came and stood at the altar, having a **golden censer**; and there was given unto him much incense, that **he should offer [it] with the prayers of all saints upon the golden altar which was before the throne**. And the smoke of the incense, [which came] with the prayers of the saints, ascended up before God out of the angel's hand.

QUESTIONS THAT NEED ANSWERS

- **WHERE IS JESUS AT THE BEGINNING OF THE SERIES OF THE SEVEN TRUMPETS ACCORDING TO THIS TEXT ?**
- **AND WHAT'S HE (JESUS) DOING THERE ACCORDING TO THIS TEXT?**

REVELATION'S PATTERN OF CHRIST AMIDST THE HEBREW SANCTUARY THE HOLY PLACE

HOLY PLACE:

THREE GOLD MEDALS OF SANCTIFICATION

- CANDLESTICKS RECEIVES OIL AND IMPARTS LIGHT (WHICH REPRESENTS THE CHURCH GIVING WITNESS TO JESUS THROUGH THE POWER OF THE HOLY SPIRIT) JOHN 8:12; 9:5
- THIS MEANS THAT JESUS IS THE SUN AND HIS FAITHFUL FOLLOWERS ARE MOONS—REFLECTORS
- WITHOUT HIM (CHRIST) WE CAN DO NOTHING!

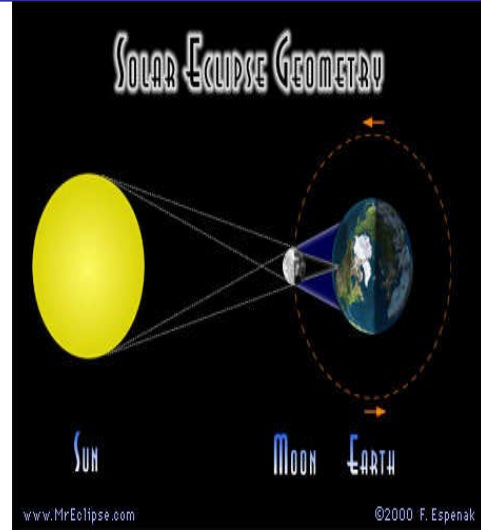
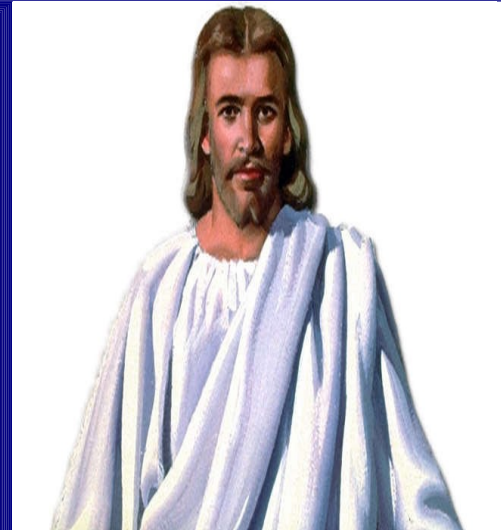

REVELATION'S PATTERN OF CHRIST AMIDST THE HEBREW SANCTUARY THE HOLY PLACE

HOLY PLACE: THREE GOLD MEDALS OF SANCTIFICATION

• THE TABLE OF SHOWBREAD REPRESENTS THE WORD OF GOD. FAITHFUL FOLLOWERS OF CHRIST SHOULD BE CONTINUALLY BE FEEDING UPON HIS WORD.

• JESUS IS THE ONLY LIVING BREAD
—JOHN 6:31-32, 48, 51

• THREE ESSENTIALS WHICH ARE VITAL FOR SPIRITUAL NOURISHMENT:

v. HOLY SPIRIT

λ. HOLY SCRIPTURES

ρ. SPIRIT OF PROPHECY BOOKS

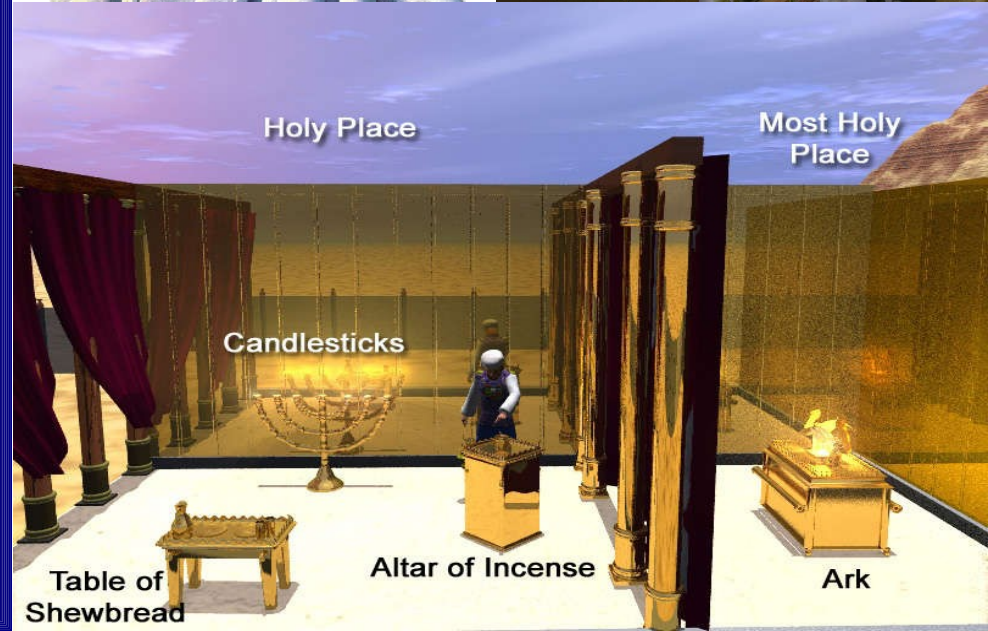
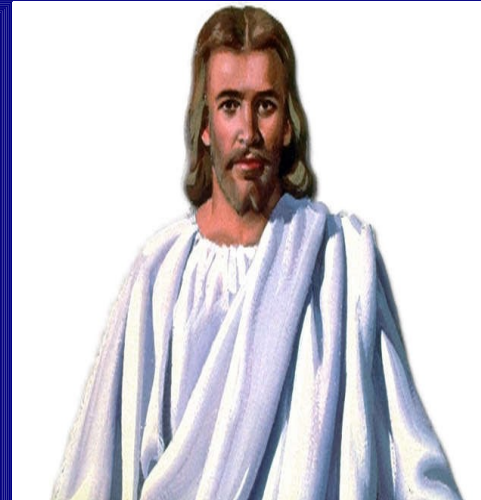

REVELATION'S PATTERN OF CHRIST AMIDST THE HEBREW SANCTUARY THE HOLY PLACE

HOLY PLACE: THREE GOLD MEDALS OF SANCTIFICATION

• THE ALTAR OF INCENSE
REPRESENTS THE
PRAYERS OF THE
WITH THE MERITS
WHICH WOULD EN
PRAYERS TO BE AC
UNTO GOD

• 1 THESSALONIANS

1 SAMUEL 12:23

PSALMS 55:17

JOHN 14:6



REVELATION'S PATTERN OF CHRIST AMIDST THE HEBREW SANCTUARY THE HOLY PLACE

HOLY PLACE: A MUST-TO-DO LIST

- WITNESSING TO OTHERS WITH THE HELP OF THE HOLY OIL—TESTIMONY OF JESUS
- BIBLE STUDY—FEEDING ON THE WORD OF JESUS
- PRAYER—TALKING AND SPENDING QUALITY TIME ALONE WITH JESUS

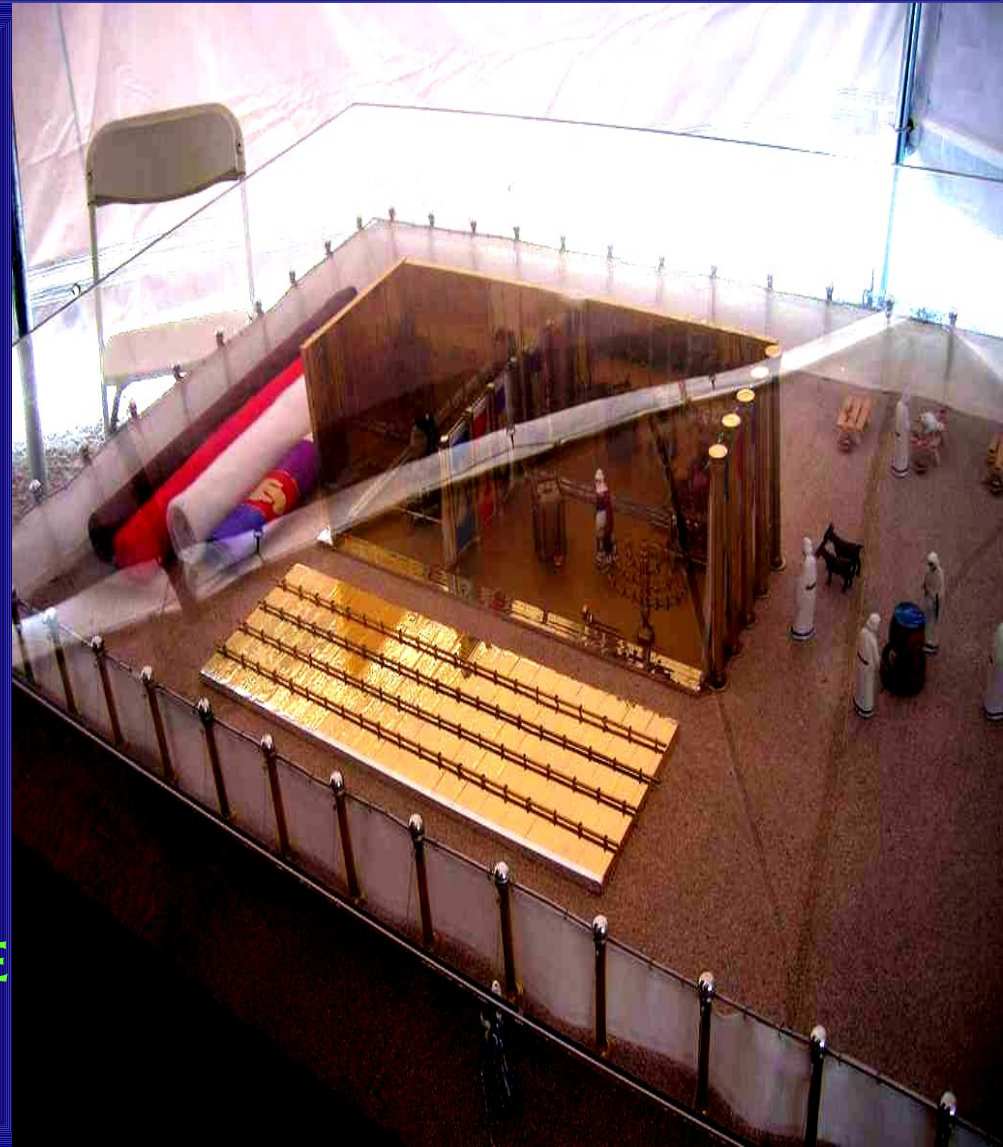

SPIRIT OF PROPHECY:

STEPS TO CHRIST, P. 101

**PRAYER WITHOUT EARNEST
ACTIVITY FOR OTHERS LEADS TO
FORMALISM**

The life must be like Christ's life,—between the mountain
and the multitude. He who does nothing but pray will soon
cease to pray, or his prayers will become a formal routine.

REVELATION'S PATTERN OF CHRIST AMIDST THE HEBREW SANCTUARY THE MOST HOLY PLACE

REVELATION 11:19

And the temple of God was opened in heaven, and there was seen in his temple the ark of his testament: and there were lightnings, and voices, and thunderings, and an earthquake, and great hail.



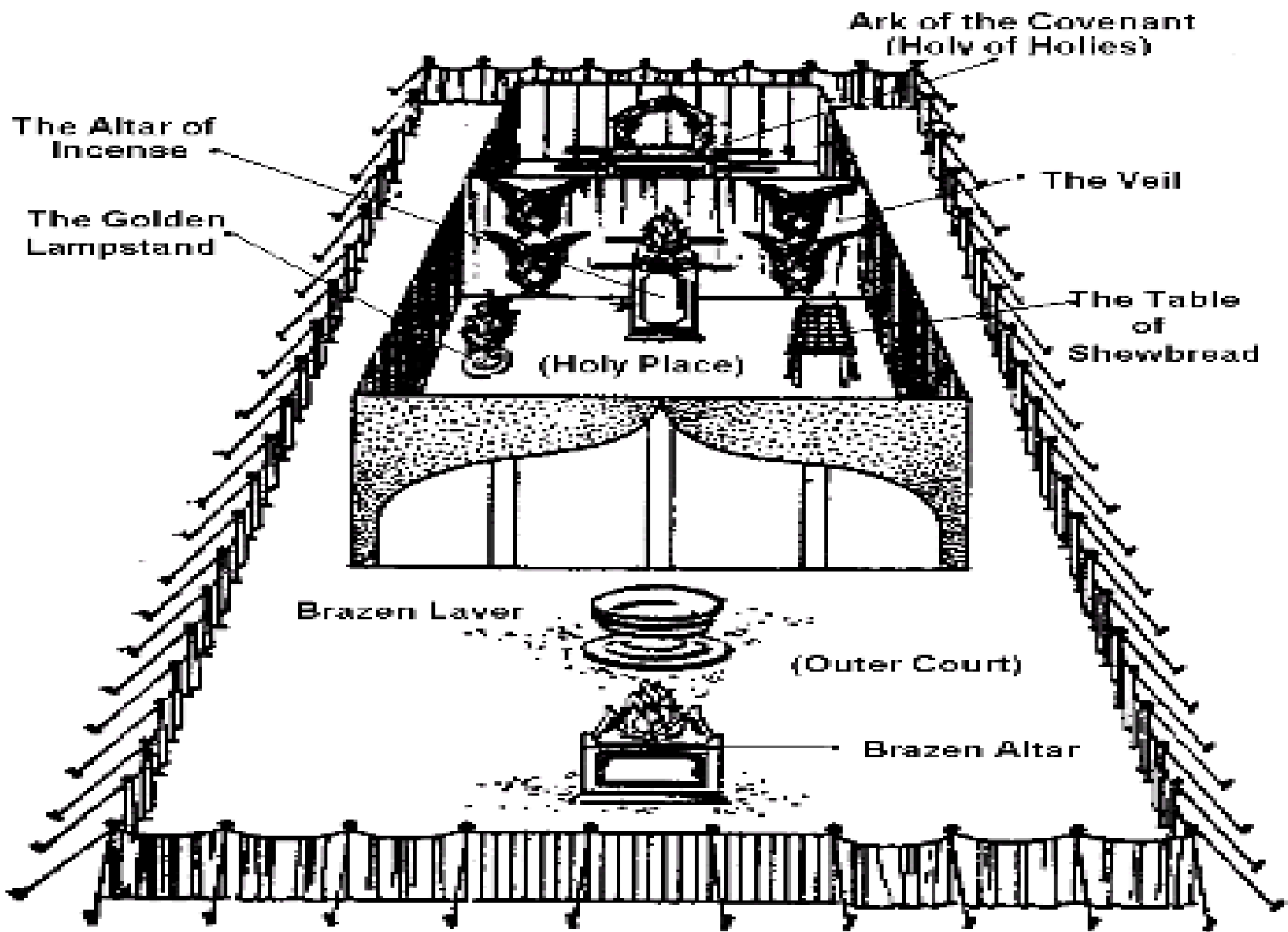



THOU SHALT HAVE NO
OTHER GODS BEFORE ME

THOU SHALT NOT MAKE
UNTO THEE ANY GRAVEN
IMAGE OR ANY LIKENESS
OF ANY THING

THOU SHALT NOT TAKE
THE NAME OF THE LORD
THY GOD IN VAIN

REMEMBER THE SABBATH
DAY TO KEEP IT HOLY SIX
DAYS SHALT THOU LABOR
AND DO ALL THY WORK BUT
THE SEVENTH DAY IS THE

HONOR THY FATHER AND
THY MOTHER

THOU SHALT NOT KILL

THOU SHALT NOT COMMIT
ADULTERY

THOU SHALT NOT STEAL

THOU SHALT NOT BEAR
FALSE WITNESS AGAINST
THY NEIGHBOR

THOU SHALT NOT COVET

REVELATION'S PATTERN OF CHRIST AMIDST THE HEBREW SANCTUARY THE MOST HOLY PLACE

REVELATION 11:19

And the temple of God was opened in heaven, and there was seen in his temple the ark of his testament: and there were lightnings, and voices, and thunderings, and an earthquake, and great hail.

QUESTIONS THAT NEED ANSWERS

- WHERE IS JESUS IN RELATION TO THIS TEXT?
- WHAT GOOD WOULD IT DO FOR JESUS TO GO INTO THE MOST HOLY PLACE AND BEGIN THE WORK OF JUDGMENT IN HEAVEN, AND MEANWHILE, NO ONE ON EARTH KNOWS NOTHING ABOUT IT?



REVELATION'S PATTERN OF CHRIST AMIDST THE HEBREW SANCTUARY THE MOST HOLY PLACE

REVELATION 14:6, 7

And I saw another angel fly in the midst of heaven, having the everlasting gospel to preach unto them that dwell on the earth, and to every nation, and kindred, and tongue, and people, Saying with a loud voice, Fear God, and give glory to him; for the hour of his judgment is come: and worship him that made heaven, and earth, and the sea, and the fountains of waters.

N:B: AN EARTHLY
ANNOUNCEMENT OF THIS
HEAVENLY EVENT

N:B: CREATION IS OFTEN
CONNECTED WITH JUDGMENT,
WHY?

BECAUSE ALL OF GOD'S
CREATURES ARE ACCOUNTABLE
TO THEIR CREATOR

QUESTION THAT NEEDS ANSWERS

WHAT HAPPENS AFTER THE WORK
IN THE MOST HOLY PLACE COMES
TO AN END?

READ: REVELATION 15:5-8

WHAT WAS—IS THE TRUMPET USED FOR?

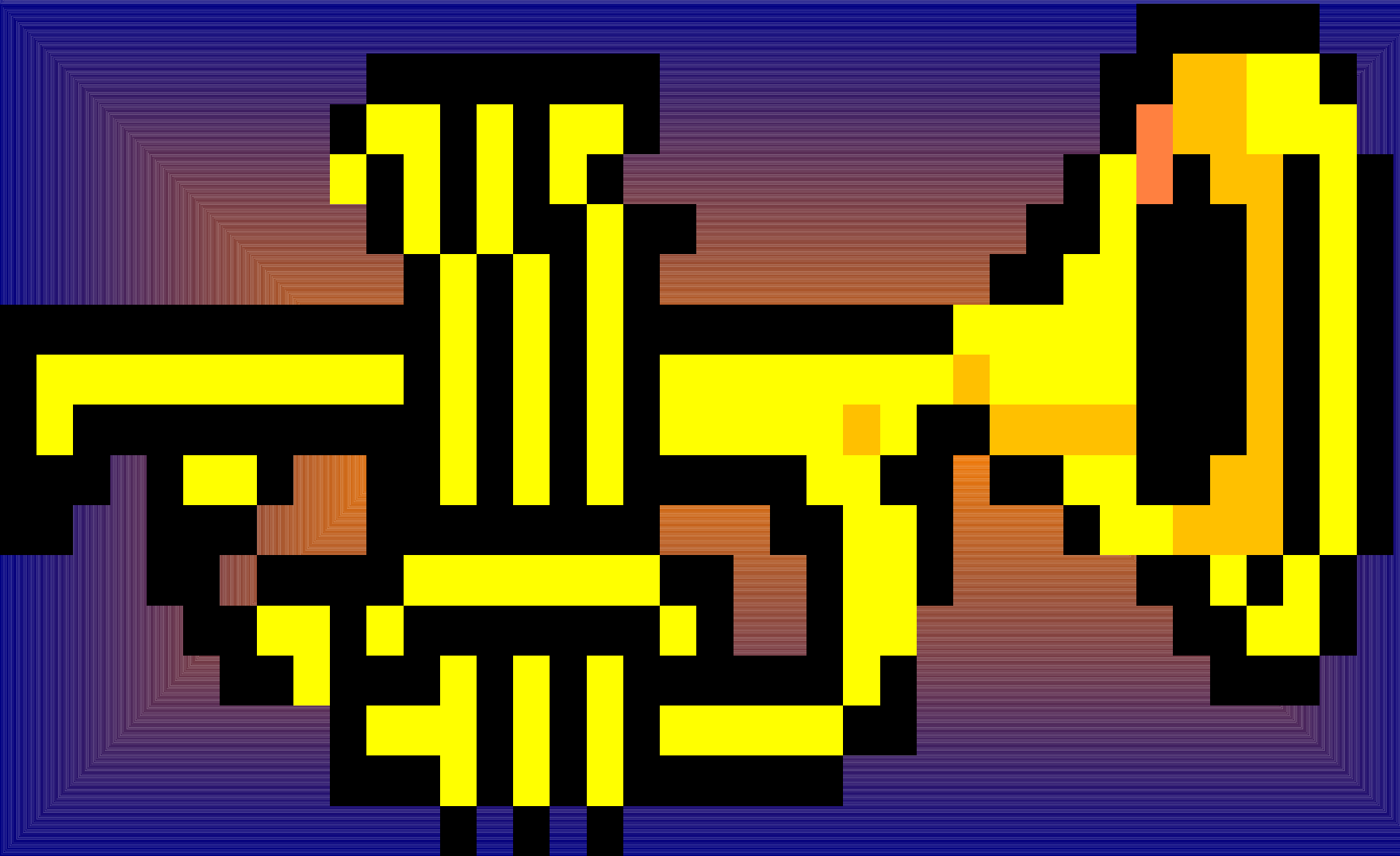

HENCE, WHAT IS PRESENT TRUTH?

**TEACHING AND PREACHING PRESENT TRUTH
IS WITHIN THE CONTEXT OF WHERE JESUS IS
RIGHT NOW (IN THE MOST HOLY PLACE) AND
THE INTERCESSORY WORK THAT HE IS
DOING THERE EVEN AS YOU ARE READING
THIS...**

SPIRIT OF PROPHECY: EARLY WRITINGS, PP. 54-56

I saw the Father rise from the throne, [SEE PAGE 92.] and in a flaming chariot go into the holy of holies within the veil, and sit down. Then Jesus rose up from the throne, and the most of those who were bowed down arose with Him. I did not see one ray of light pass from Jesus to the *careless multitude* after He arose, and they were left in perfect darkness. Those who arose when Jesus did, kept their eyes fixed on Him as He left the throne and led them out a little way. Then He raised His right arm, and we heard His lovely voice saying, "Wait here; I am going to My Father to receive the kingdom; keep your garments spotless, and in a little while I will return from the wedding and receive you to Myself." Then a cloudy chariot, with wheels like flaming fire, surrounded by angels, came to where Jesus was.

He stepped into the chariot and was borne to the holiest, where the Father sat. There I beheld Jesus, a great High Priest, standing before the Father. On the hem of His garment was a bell and a pomegranate, a bell and a pomegranate. Those who rose up with Jesus would send up their faith to Him in the holiest, and pray, "My Father, give us Thy Spirit." Then Jesus would breathe upon them the Holy Ghost. In that breath was light, power, and much love, joy, and peace. I turned to look at the company who were still bowed before the throne; they did not know that Jesus had left it. Satan appeared to be by the throne, trying to carry on the work of God. I saw them look up to the throne, and pray, "Father, give us Thy Spirit." Satan would then breathe upon them an unholy influence; in it there was light and much power, but no sweet love, joy, and peace. Satan's object was to keep them deceived and to draw back and deceive God's children.

REVELATION'S PATTERN OF CHRIST AMIDST THE HEBREW SANCTUARY THE MOST HOLY PLACE

REVELATION 15:5, 6

And after that I looked, and, behold, the temple of the tabernacle of the testimony in heaven was opened: And the seven angels came out of the temple, having the seven plagues, clothed in pure and white linen, and having their breasts girded with golden girdles.

N:B: NO—TIME THE MOST HOLY PLACE IS OPENED NOT FOR PRAYERS TO ASCEND BUT FOR PLAGUES TO DESCEND

REVELATION 15:7, 8

And one of the four beasts gave... the seven angels seven golden vials full of the wrath of God, ... And the temple was filled with smoke from the glory of God, ... and no man was able to enter into the temple, till the seven plagues of the seven angels were fulfilled.



**GOD'S PEOPLE- LIVING WITHOUT
AN INTERCESSOR?**

**THEY ARE LIVING WITHOUT AN INTERCESSOR
—BUT NOT LIVING WITHOUT A PROTECTOR**

MATTHEW 28:20

**...and, lo, I am with you alway, even| unto the
end of the world.**

REVELATION CHAPTERS - 16-18

**TALK ABOUT THE OUTPOURING OF THE
SEVEN LAST PLAGUES**

**WHY ARE THOSE SEVEN
LAST PLAGUES POURED
OUT?**

THE ANSWER IS IN THIS STORY

1 SAMUEL 5:8-12

They sent therefore and gathered all the lords of the Philistines unto them, and said, What shall we do with the ark of the God of Israel? And they answered, Let the ark of the God of Israel be carried about unto Gath. And they carried the ark of the God of Israel about [thither]. And it was [so], that, after they had carried it about, the hand of the LORD was against the city with a very great destruction: and he smote the men of the city, both small and great, and they had emerods in their secret parts. Therefore they sent the ark of God to Ekron. And it came to pass, as the ark of God came to Ekron, that the Ekronites cried out, saying, They have brought about the ark of the God of Israel to us, to slay us and our people. So they sent and gathered together all the lords of the Philistines, and said, Send away the ark of the God of Israel, and let it go again to his own place, that it slay us not, and our people: for there was a deadly destruction throughout all the city; the hand of God was very heavy there. And the men that died not were smitten with the emerods: and the cry of the city went up to heaven.

THE SECOND COMING OF JESUS
CHRIST IS RECORDED IN
REVELATION 19:11-16

NOTICE:

THE SCAPEGOAT CEREMONY WAS THE LAST CEREMONY TO HAVE TAKEN PLACE IN THE HEBREW SANCTUARY SERVICE.

IT TOOK PLACE AT THE VERY END OF THE SANCTUARY CEREMONY, OUTSIDE THE ENTRANCE DOOR OF THE TABERNACLE.

➤ LEVITICUS 16:8-10, 21, 22

➤ REVELATION 19:1-10

➤ REVELATION 20:1-3

REVELATION'S PATTERN OF CHRIST AMIDST THE HEBREW SANCTUARY

THE MOST HOLY PLACE WOULD BE CLOSED FOR BUSINESS AFTER THE PRONOUNCEMENT OF REVELATION 22:11

LEVITICUS 16:21, 22

And Aaron shall lay both his hands upon the head of the live goat, and confess over him all the iniquities of the children of Israel, and all their transgressions in all their sins, putting them upon the head of the goat, and shall send [him] away by the hand of a fit man into the wilderness: And the goat shall bear upon him all their iniquities unto a land not inhabited: and he shall let go the goat in the wilderness.

QUESTIONS THAT NEED ANSWERS

3. WHERE IS THE DEVIL GOING TO BE DURING 1000 YEARS?
4. WILL HE HAVE ANY ONE TO TEMPT DURING THAT TIME?
3. WHAT WILL BE THE STATE OF THIS WORLD DURING HIS IMPRISONMENT? JEREMIAH 4:23-26

REVELATION'S PATTERN OF CHRIST AMIDST THE HEBREW SANCTUARY

THE MOST HOLY PLACE IS NOW OPEN-FOR-BUSINESS:

JOHN 14:1-3

JOHN 14:1-3

Let not your heart be troubled: ye believe in God, believe also in me. **In my Father's house are many mansions: if [it were] not [so], I would have told you. I go to prepare a place for you. And if I go and prepare a place for you, I will come again, and receive you unto myself; that where I am, [there] ye may be also.**

QUESTIONS THAT NEED ANSWERS

- WHY ARE THE DISCIPLES' HEARTS TROUBLED?
- WERE THOSE MANSIONS ALREADY THERE—OR DID JESUS HAVE TO DO SOME HEAVENLY CONTRACTING?
- JESUS WENT TO HEAVEN TO DO WHAT?
- DOES THE BOOKS OF HEBREWS & REVELATION EXPLAIN THE WORK THAT JESUS IS DOING RIGHT NOW IN THE HEAVENLY SANCTUARY?

REVELATION'S PATTERN OF CHRIST AMIDST THE HEBREW SANCTUARY

THE MOST HOLY PLACE IS NOW OPEN-FOR-BUSINESS: JOHN 14:1-3

QUESTIONS THAT NEED ANSWERS

➤ IS THERE A WORK THAT JESUS HAS TO PERFORM PRIOR TO HIS RETURN?

N:B: WHILE JESUS IS PREPARING A PLACE UP THERE (HEAVEN) SHOULD GOD'S PEOPLE BE PREPARING THEMSELVES DOWN HERE (EARTH)?

N:B: THE BOOK OF REVELATION AND HEBREWS SPEAK OF JESUS PREPARING A WORK IN HEAVEN

➤ WHERE DOES THE BIBLE SPEAK OF A PARALLEL WORK THAT GOD'S FAITHFUL PEOPLE OUGHT TO BE DOING DOWN HERE?

CHRISTIANS HOMEWORK: JOHN CHAPTERS 14-17

REVELATION'S PATTERN OF CHRIST AMIDST THE HEBREW SANCTUARY

THE MOST HOLY PLACE IS NOW OPEN-FOR-BUSINESS:

JOHN 14:1-3

QUESTIONS THAT NEED ANSWERS

➤ WHAT ARE THE CENTRAL THEMES ON JOHN CHAPTERS 14-17 BASED UPON?

➤ GOD'S PEOPLE SHOULD CONTINUALLY BE STUDYING DAILY HIS WORD—COUPLED WITH THE HOLY SPIRIT

➤ GOD'S PEOPLE SHOULD CONTINUALLY BE PRAYING FOR OTHERS AND THEMSELVES—THAT CHRIST WILL ATONE FOR THEIR SINS

➤ GOD'S PEOPLE SHOULD CONTINUALLY BE WITNESSING (EVEN IN THE MOST DIFFICULT OF TIMES) ABOUT GOD'S SAVING GRACE

➤ **JOHN CHAPTERS 14-17 DESCRIBE HOW WE MUST HERE (EARTH) PREPARE TO LIVE UP THERE (HEAVEN)**

**REVELATION'S PATTERN OF
CHRIST AMIDST THE HEBREW
SANCTUARY
THE MOST HOLY PLACE
THAT'S PRESENT TRUTH
MESSAGE!**

**ARE YOU HEARING THESE
TRUTHS FROM YOUR
MINISTER'S PULPIT?
2 TIMOTHY 3:1-5- READ IT!**

**SPIRIT OF PROPHECY:
EARLY WRITINGS, p. 63**

**There are many precious truths
contained in the Word of God, but it is
"present truth" that the flock needs now.**

JESUS: MOST HOLY PLACE—PRESENT TRUTH SERMONS

*Thy Way O Lord is
in the Sanctuary*

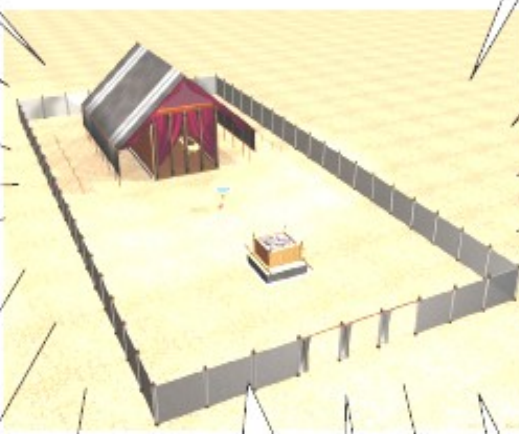

NEW EARTH
Gen 3:17; Num 35:33;
Deut 15:23; Lev 7:11-13;
Lev 4:7,18,25,30
Jer 9:21; Ex 15:23;
Lev 14:4-7
I Kings 4:33; Num 19:6
John 19:29; Lev 15:23,24

THE SABBATH
Ex 25:30
I Chron 9:32
Lev 24:5-9
Rev 11:19

THE LAW OF GOD
Ex 25:21
Ex 31:18
Rev 11:19

REPENTANCE
Lev 4:27-29
Every Sin Offering

FATE OF THE WICKED
Ps 73:12-17
Lev 3:14-17
Lev 16:25
Ps 37:20
Lev 4:8-12
Lev 6:10,11
Mal 4:3

MILLENNIUM
Lev 16:20-22
Job 1:7; Jer 4:23-27
Eze 28:19; Lev 6:9-11
Isa 24:21,22; Jer 4:28

COMMUNITY WORK
Ex 22:22-24
Deut 14:29
Deut 24:19-21
Isa 58:7-12

SECOND ADVENT
Lev 16:20-25
Isa 63:1-6
Rev 19:16
Zeph 2:1-3

SPIRITUAL GIFTS
Ex 28:30
Num 27:21
I Sam 28:6
I Sam 23:9-12

ORDER
I vol 5: p 274
Num 4:17-20
I Sam 6:19,20
II Sam 6:6-7; 12,13

TITHING
Lev 27:30-34
Num 18:26,28
Hab 7:1,2; 6:20
John 8:39

CHRISTIAN EDUCATION
Ex 12:26-27, 13:8,14
Deut 32:7; 4:9,10; 6:7-9
Joshua 4:6-7
Psalms 78:6,7

RIGHTEOUSNESS BY FAITH
Lev 16:13; Rev 8:3
Gt Cont. p 421
Deut 15:19,21
Lev 22:24,25

JUDGEMENT
Eccl 12:13,14
Jer 17:12
Dan 7:9,10

MINISTRY OF ANGELS
Ex 25:20, 36:8,35
Dan 7:9,10

LIFE ONLY THROUGH CHRIST
Lev 4:29; Rom 6:23

HEALTH REFORM
Lev 23:27-29
Gt Cont. p 420.
Isa 58:5; Luke 21:34-36
Isa 22:12-14; 66:15-17
Deut 25:12-14

THE LORD'S SUPPER
Gen 14:18;
Lev 7:15-21; 19:5-8
John 11:39
Ps 16:8-10
Acts 2:24-27,30

DRESS REFORM
Num 15:37-39;
Deut 22:5; Lev 19:19
Isa 3:16-24; I Pet 3:3-5
I Tim 2:9; Gen 35:1-5
Joshua 7:20,21,11

BAPTISM
John 1:25
Ex 40:12-16; 30:17-20
I Cor 10:1,2

ARE YOU FOLLOWING JESUS' PATTERN THROUGH OUT THE HEBREW SANCTUARY...?

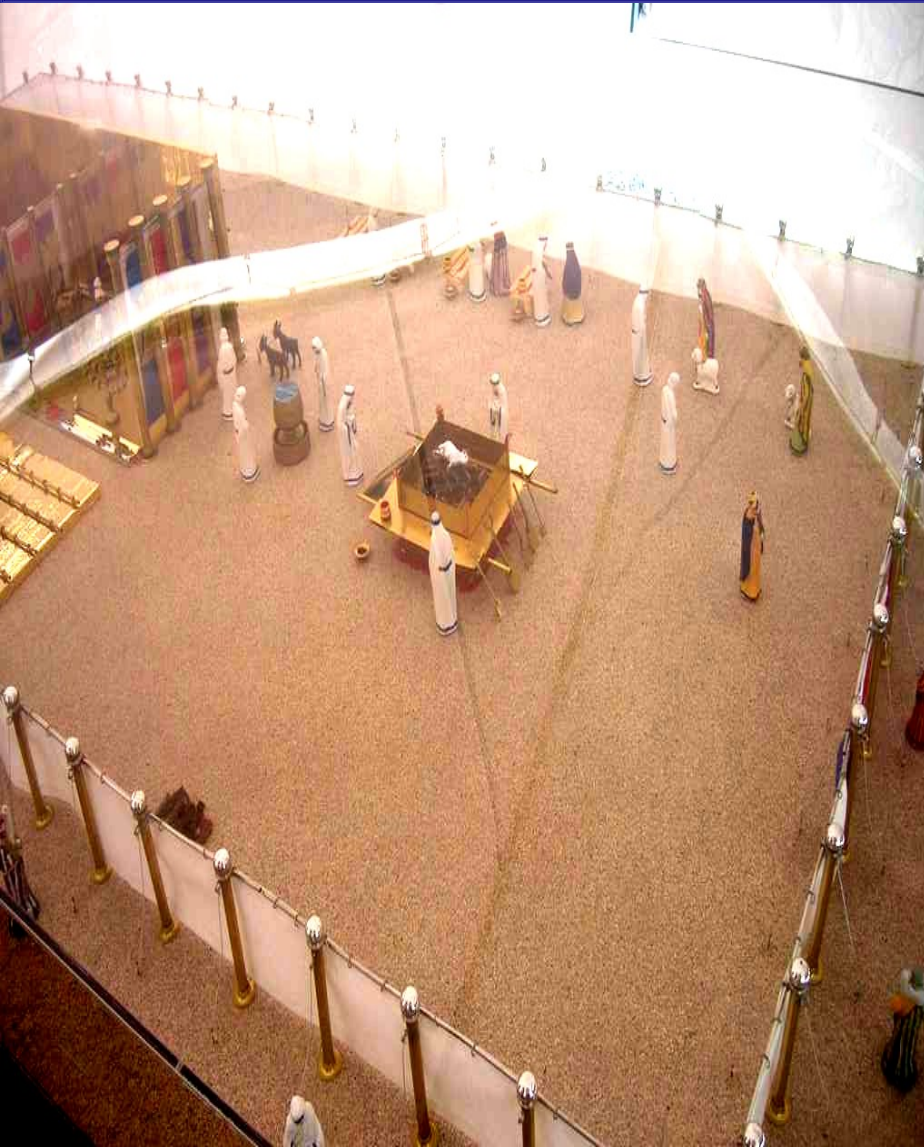

ARE YOU LIVING JESUS' PATTERN THROUGH OUT
GOD'S HUMAN TEMPLE?



**ARE YOU SPIRITUALLY & LITERALLY PREPARING YOURSELF
AND OTHERS TO BE WITH JESUS IN THAT HEAVENLY
SANCTUARY?**



THE SANCTUARY

It is my prayer that each of us will be in that circle of God's love, in joyful relationship with Jesus. When we are, we will want to tell our friends and anyone else about it. Heaven will begin right here in our hearts (John 5:24)

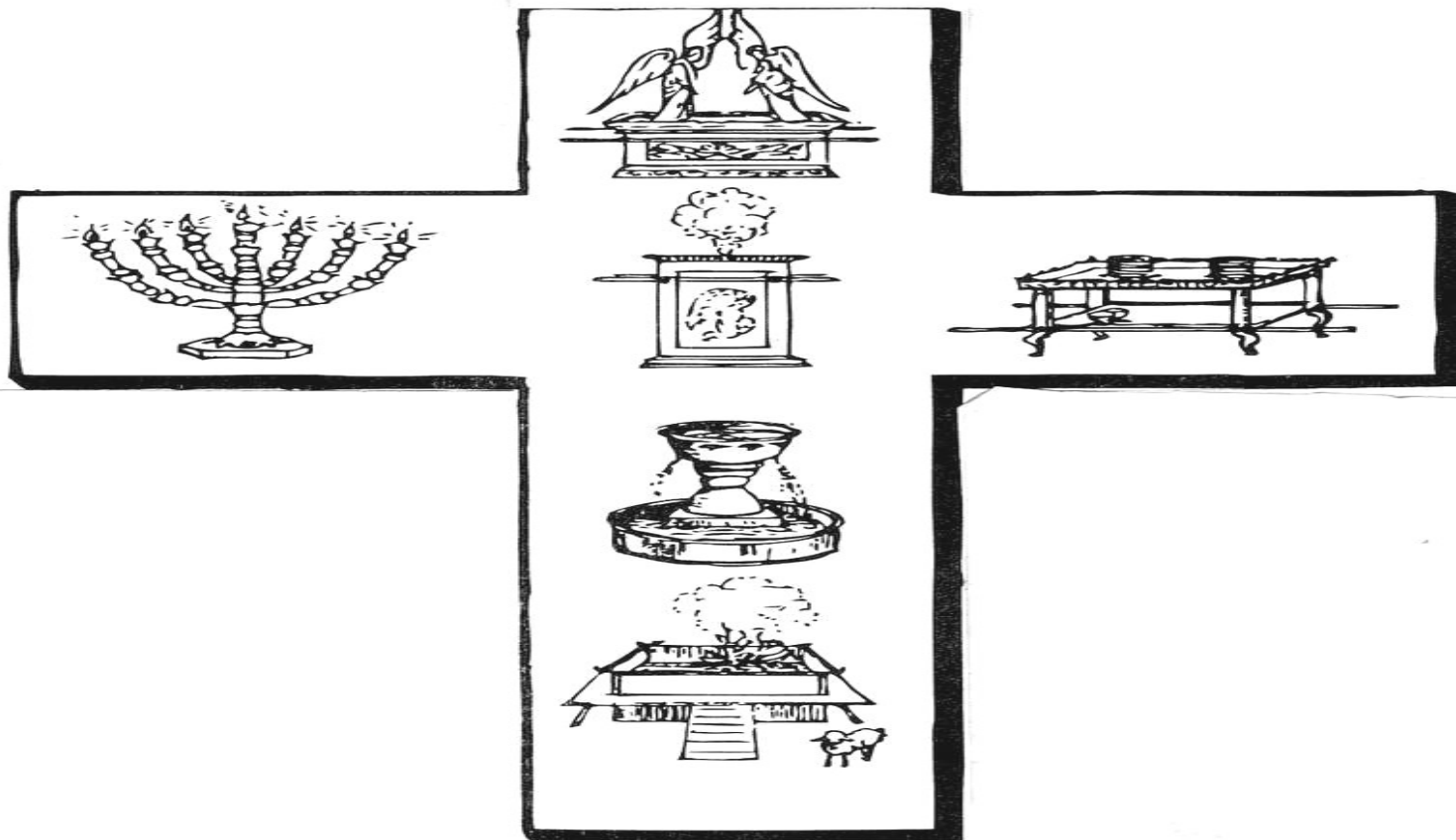

The *sanctuary* furniture from the *bronze altar* in the court to the *ark* in the *Most Holy Place* is laid out in the form of a cross. Walking through the *sanctuary* spiritually is following a path from Eden lost back to the *throne* of God.

CLICK ON THE AUDIO ICON TO LISTEN AS JESUS TAKES US BACK AND FORTH IN THE SANCTUARY ON EARTH AND ABOVE

THE SANCTUARY

It is my prayer that each of us will be in that circle of God's love, in joyful relationship with Jesus. When we are, we will want to tell our friends and anyone else about it. Heaven will begin right here in our hearts (John 5:24)

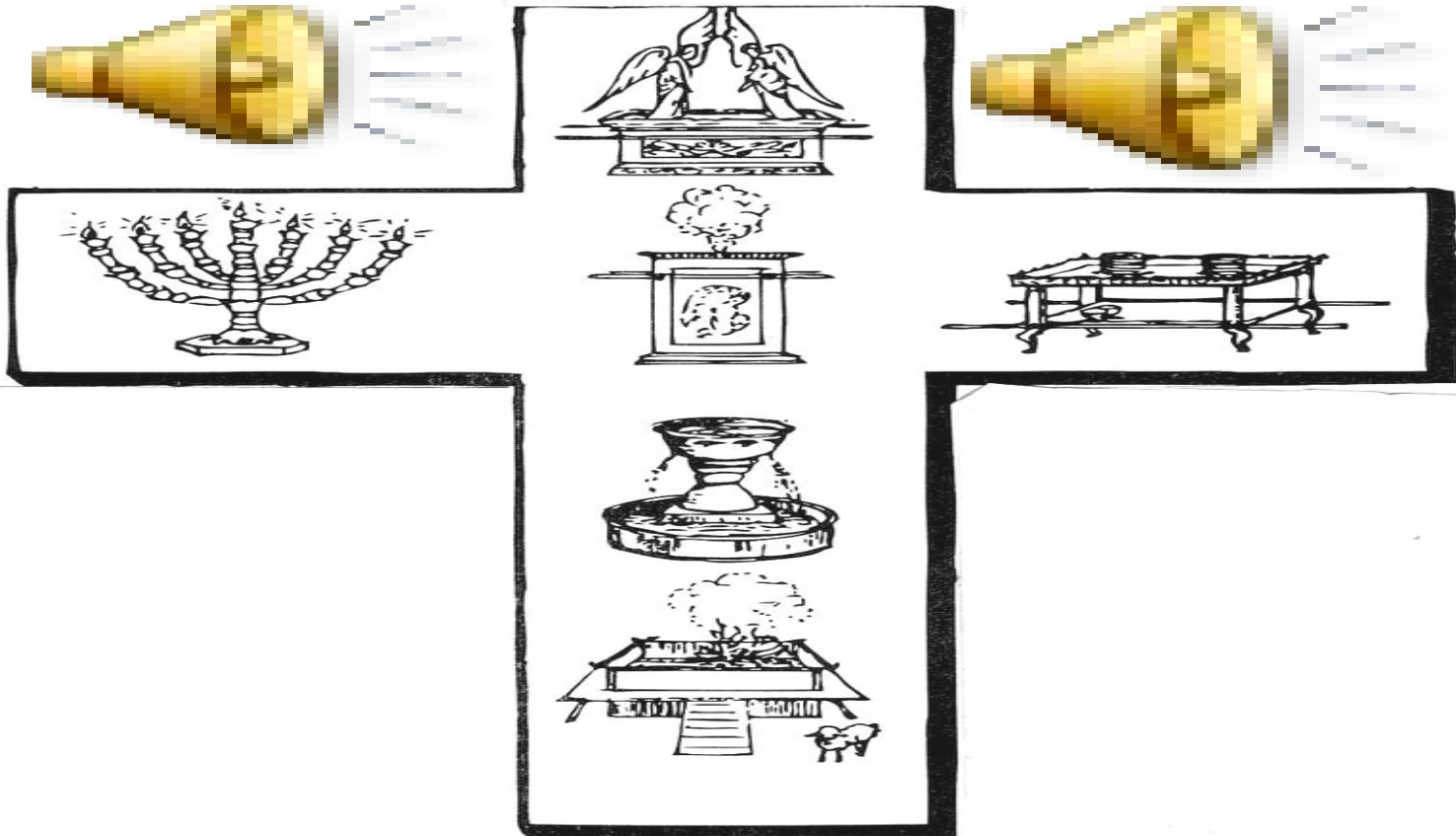

The *sanctuary* furniture from the *bronze altar* in the court to the *ark* in the *Most Holy Place* is laid out in the form of a cross. Walking through the *sanctuary* spiritually is following a path from Eden lost back to the *throne* of God.

**WAIT AS THE STICKMAN BIDS YOU
GOODBYE!**

**VISIT THESE ONLINE RELATED POWERPOINT AND
VIDEO LINKS:**

<http://www.jesusfilm.org/film-and-media/watch-t>

<http://vimeo.com/14483688>

http://www.4shared.com/u/oB0tWvjC/JESUS_CHRIS

**WAIT AS THE STICKMAN BIDS YOU
GOODBYE!**